



N.B. For the correct choice of the gearmotor, please refer to the tables on page 118. These geared motors require a running-in period. Therefore, during the first 30 working hours, the resulting torque will be lower than the values given. On request, the motor can be supplied with electromagnetic brake at 24 Vdc, marked with letter KB (MCCKB), see specifications on page 120.

N.B. Para una correcta selección del motorreductor se aconseja ajustarse a las tablas presentadas en la página 118. Estos motorreductores necesitan un cierto rodaje. Por lo tanto, en las primeras 30 horas de funcionamiento, se notará un par menor que los datos presentados. A petición es posible suministrar el motor con freno electromagnético alimentado con 24 Vdc, que se distingue por las letras KB (MCCKB), ver características en la pág. 120.

WORM GEAR MOTOR

MP MOTOR: Direct Current with permanent magnets. Totally enclosed with external ventilation. Class F windings. Power supply with 12 or 24 Vdc. Max. absorbed power 60 W. IP65 protection according to CEI EN 60529.

MP3N-MP4N MOTOR: Direct Current with permanent magnets. Totally enclosed without external ventilation. Class F windings. Power supply with 12 or 24 Vdc. Max. absorbed power 230 W. IP65 protection according to CEI EN 60529.

GEAR UNIT: With die-cast aluminum housing. Worm Center Distance 1.024 inches. CARO bronze gear ring with 120-160 HB hardness. Hardened steel worm with ground threads rotating on ball and roller bearings. Lubricated with synthetic oil. High temperature oil seals. 9 reduction gear ratios (i) are available from 7.5 to 80. Maximum rated torque 79.6 in-lbs. Versions B3 and B5. B5/S Left Version – B5/D Right Version.

MOTORREDUCTOR CON TORNILLO SIN FIN

MOTOR MP: de corriente continua con imanes permanentes, en forma cerrada con ventilación externa. Aislamiento clase F. Alimentación con 12 ó 24 Vcc. Potencia absorbida 60 W. Protección IP 65 según normas CEI EN 60529.

MOTOR MP3N-MP4N: de corriente continua con imanes permanentes, en forma cerrada sin ventilación externa. Aislamiento clase F. Alimentación con 12 ó 24 Vdc. Potencia máx. absorbida 230 W. Protección IP 65 según normas CEI EN 60529.

REDUCTOR: con carcasa de aluminio inyectado a presión. Distancia entre ejes 1.024 in. Corona de bronce CARO, dureza 120÷160 HB. Tornillo de acero templado con filete rectificado que gira sobre cojinetes de bolas. Lubricación con aceite especial de larga duración. Retenes de estanqueidad de goma especial para altas temperaturas. Las relaciones de reducción disponibles (i) son 9, de 7.5 a 80. Par nominal 9 79.6 in lbs. Versión B3 ó B5. B5/S izquierdo - B5/D derecho.



Type	Ratio	Absorbed power	Delivered power	Input r.p.m.	Output r.p.m.	Rated torque	Voltage	Current
Tipo	Relación	Potencia absorbida	Potencia entregada	Revoluciones entrada	Revoluciones salida	Par nominal	Tensión	Intensidad
	i	W	HP	rpm	rpm	in-lbs	V	A
MCC 12MP	7.5	60	1/20	2800	373	5.3	12	5
MCC 24MP	7.5	60	1/20	2800	373	5.3	24	2.5
MCC 12MP3N	7.5	115	1/10	2800	373	15.0	12	9.6
MCC 12MP4N	7.5	230	1/5	2800	373	30.1	12	19.2
MCC 24MP3N	7.5	115	1/10	2800	373	15.0	24	4.8
MCC 24MP4N	7.5	230	1/5	2800	373	30.1	24	9.6
MCC 12MP	10	60	1/20	2800	280	7.1	12	5
MCC 24MP	10	60	1/20	2800	280	7.1	24	2.5
MCC 12MP3N	10	115	1/10	2800	280	20.3	12	9.6
MCC 12MP4N	10	230	1/5	2800	280	40.7	12	19.2
MCC 24MP3N	10	115	1/10	2800	280	20.3	24	4.8
MCC 24MP4N	10	230	1/5	2800	280	40.7	24	9.6
MCC 12MP	15	60	1/20	2800	186	9.7	12	5
MCC 24MP	15	60	1/20	2800	186	9.7	24	2.5
MCC 12MP3N	15	115	1/10	2800	186	29.2	12	9.6
MCC 12MP4N	15	230	1/5	2800	186	58.4	12	19.2
MCC 24MP3N	15	115	1/10	2800	186	29.2	24	4.8
MCC 24MP4N	15	230	1/5	2800	186	58.4	24	9.6
MCC 12MP	20	60	1/20	2800	140	12.4	12	5
MCC 24MP	20	60	1/20	2800	140	12.4	24	2.5
MCC 12MP3N	20	115	1/10	2800	140	36.3	12	9.6
MCC 12MP4N	20	230	1/5	2800	140	72.6	12	19.2
MCC 24MP3N	20	115	1/10	2800	140	36.3	24	4.8
MCC 24MP4N	20	230	1/5	2800	140	72.6	24	9.6
MCC 12MP	30	60	1/20	2800	93	17.7	12	5
MCC 24MP	30	60	1/20	2800	93	17.7	24	2.5
MCC 12MP3N	30	115	1/10	2800	93	50.4	12	9.6
MCC 12MP4N	30	192	1/6	2900	97	79.6	12	16
MCC 24MP3N	30	115	1/10	2800	93	50.4	24	4.8
MCC 24MP4N	30	192	1/6	2900	97	79.6	24	8
MCC 12MP	40	60	1/20	2800	70	22.1	12	5
MCC 24MP	40	60	1/20	2800	70	22.1	24	2.5
MCC 12MP3N	40	115	1/10	2800	70	61.9	12	9.6
MCC 12MP4N	40	144	1/7	2950	74	79.6	12	12
MCC 24MP3N	40	115	1/10	2800	70	61.9	24	4.8
MCC 24MP4N	40	144	1/7	2950	74	79.6	24	6
MCC 12MP	60	60	1/20	2800	46	30.1	12	5
MCC 24MP	60	60	1/20	2800	46	30.1	24	2.5
MCC 12MP3N	60	115	1/10	2800	46	79.6	12	9.6
MCC 24MP3N	60	115	1/10	2800	46	79.6	24	4.8



MCC

Type	Ratio	Absorbed power	Delivered power	Input r.p.m.	Output r.p.m.	Rated torque	Voltage	Current
Tipo	Relación	Potencia absorbida	Potencia entregada	Revoluciones entrada	Revoluciones salida	Par nominal	Tensión	Intensidad
	i	W	HP	rpm	rpm	in-lbs	V	A
MCC 12MP	70	60	1/20	2800	40	32.7	12	5
MCC 24MP	70	60	1/20	2800	40	32.7	24	2.5
MCC 12MP3N	70	98	1/11	2900	41.5	79.6	12	8.2
MCC 24MP3N	70	98	1/11	2900	41.5	79.6	24	4.1
MCC 12MP	80	60	1/20	2800	35	35.4	12	5
MCC 24MP	80	60	1/20	2800	35	35.4	24	2.5
MCC 12MP3N	80	94	1/12	2900	36	79.6	12	7.8
MCC 24MP3N	80	94	1/12	2900	36	79.6	24	3.9

(*) - Under no circumstances should the torque values marked with an asterisk be exceeded. With the higher gear ratios the motor power is considerably higher than the capacity of the gear unit.

(*) - Los valores referentes al par marcados con el asterisco, no se deben en absoluto superar, ya que, con las altas relaciones, la potencia del motor es notablemente mayor que la capacidad del reductor.

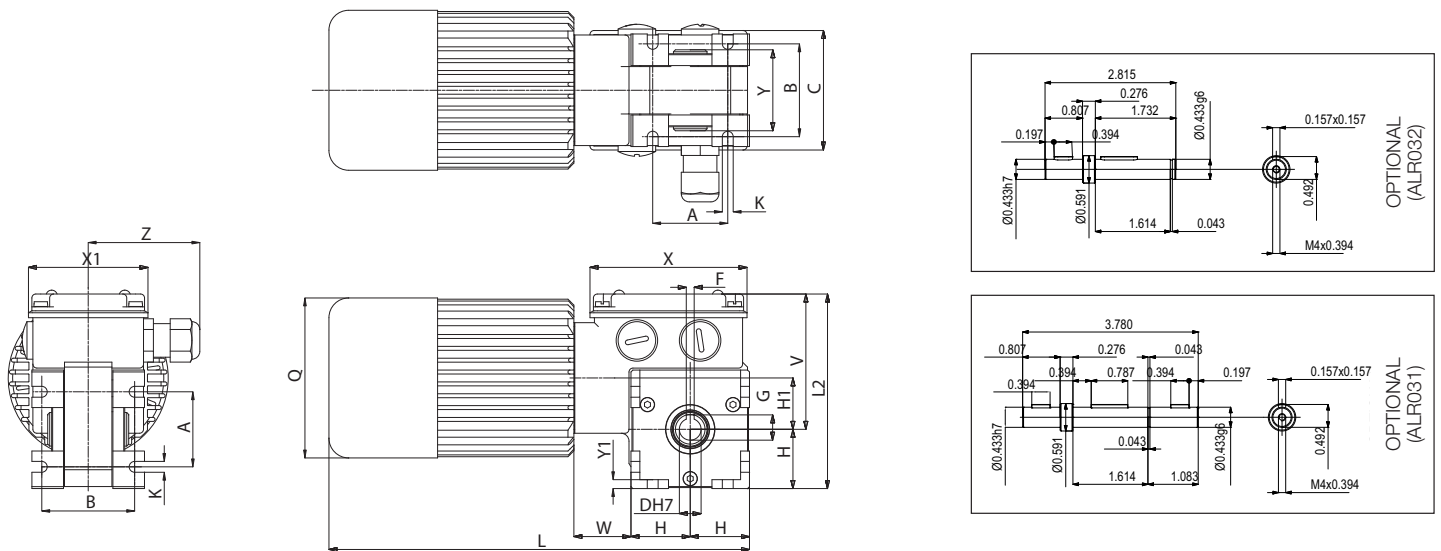

B3

Type	A	B	C	D	F	G	H	H1	K	L
Tipo										
MCC...MP	1.496	1.850	2.283	0.433	0.157	0.504	1.181	1.024	0.216	7.205

Type	L2	Q	V	X	X1	Y	Y1	W	Z	Weight
Tipo										Peso
MCC...MP	3.898	3.189	2.716	3.150	2.362	1.614	0.236	1.102	2.205	lbs
										3.53

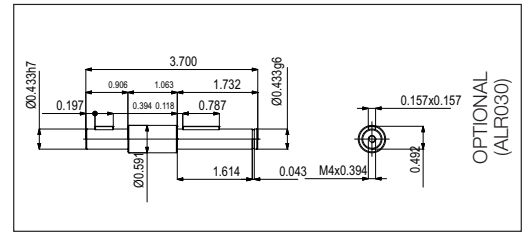
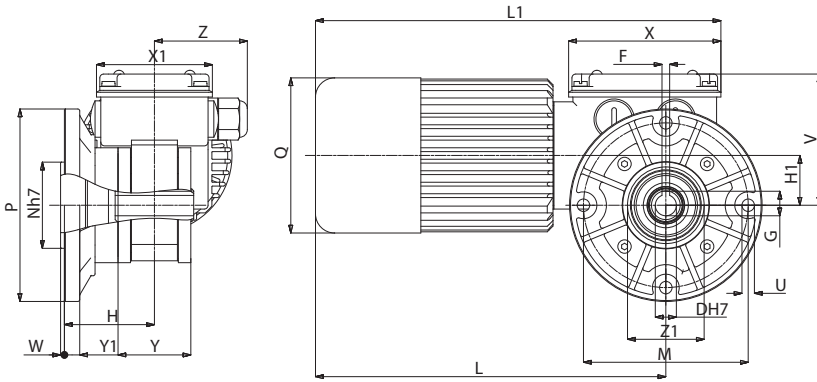

B5/S

Type Tipo	D	F	G	H	H1	L	L1	M	N	P	Q
MCC...MP	0.433	0.157	0.504	1.850	1.024	6.023	7.126	3.386	1.772	3.937	3.189

Type Tipo	U	V	X	X1	Y	Y1	W	Z	Z1	Weight Peso lbs
MCC...MP	0.256	2.716	3.150	2.362	1.614	0.315	0.079	2.205	1.575	3.97

For the self-braking version, add the letter KB to the type designation. Dimensions L, L1, increase by 1.063 in.

En la versión freno, añadir las letras KB a la sigla del tipo. Las cotas L, L1 aumentan de 1.063 in.



MCC

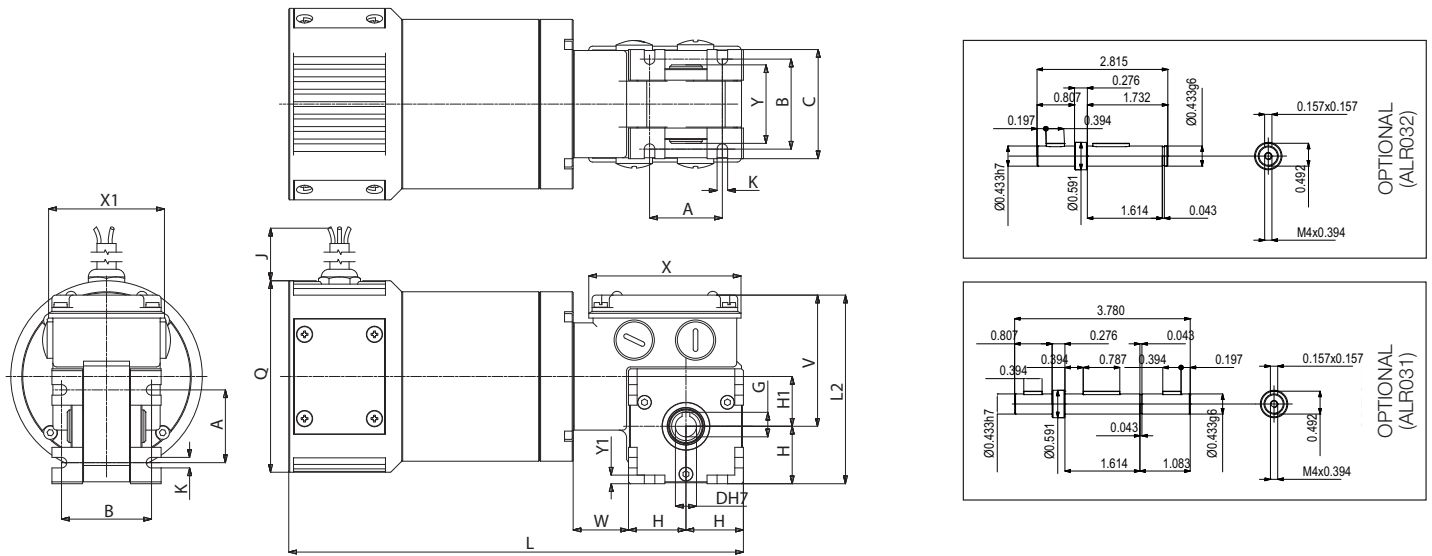

B3

Type Tipo	A	B	C	D	F	G	H	H1	J	K
MCC...MP3N	1.496	1.850	2.283	0.433	0.157	0.504	1.181	1.024	20.472	0.039
MCC...MP4N	1.496	1.850	2.283	0.433	0.157	0.504	1.181	1.024	20.472	0.039

Type Tipo	L	L2	Q	V	X	X1	Y	Y1	W	Weight Peso lbs
MCC...MP3N	9.252	3.898	3.937	2.716	3.150	2.362	1.614	0.236	1.102	9.16
MCC...MP4N	11.220	3.898	3.937	2.716	3.150	2.362	1.614	0.236	1.102	13.36

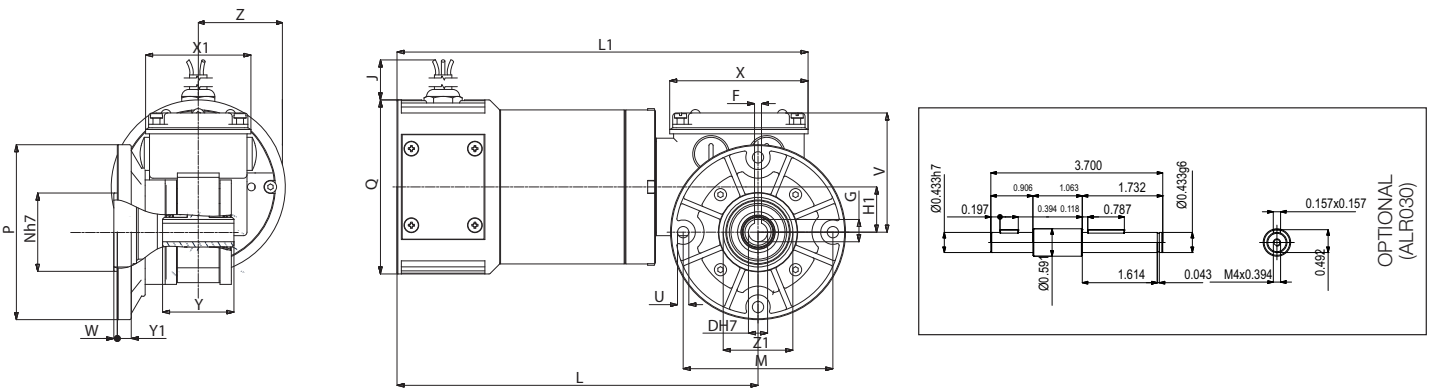

B5/S

Type Tipo	D	F	G	H	H1	J	L	L1	M	N	P
MCC...MP3N	0.433	0.157	0.504	1.850	1.024	20.472	8.071	9.213	3.386	1.772	3.937
MCC...MP4N	0.433	0.157	0.504	1.850	1.024	20.472	10.039	11.181	3.386	1.772	3.937

Type Tipo	Q	U	V	X	X1	Y	Y1	W	Z	Z1	Weight Peso lbs
MCC...MP3N	3.937	0.256	2.716	3.150	2.362	1.614	0.315	0.079	2.205	1.575	9.60
MCC...MP4N	3.937	0.256	2.716	3.150	2.362	1.614	0.315	0.079	2.205	1.575	13.80