



**N.B.** For the correct choice of the gearmotor, please refer to the tables on page 118. These gear motors require a running-in period. Therefore, during the first 30 working hours, the resulting torque will be lower than the values given. On request, motor may be supplied with electromagnetic brake at 24 Vdc, marked with letter KB (MCCEKB), see specifications on page 120.

**N.B.** Para una correcta selección del motorreductor se aconseja ajustarse a las tablas presentadas en la página 118. Estos motorreductores necesitan un cierto rodaje. Por lo tanto, en las primeras 30 horas de funcionamiento, se notará un par menor que los datos presentados. A petición es posible suministrar el motor con freno electromagnético alimentado con 24 Vdc, que se distingue por las letras KB (MCCEKB), ver características en la pág. 120.

## WORM SCREW GEAR MOTOR WITH PLANETARY REDUCTION GEAR

**MP MOTOR:** Direct Current with permanent magnets. Totally enclosed with external ventilation. Class F windings. Power supply with 12 or 24 Vdc. Max. absorbed power 60 W. IP65 protection according to CEI EN 60529.

**MP3N-MP4N MOTOR:** Direct Current with permanent magnets. Totally enclosed without external ventilation. Class F windings. Power supply with 12 or 24 Vdc. Max. absorbed power 230 W. IP65 protection according to CEI EN 60529.

**GEAR UNIT:** With die-cast aluminum worm housing reduction and steel planetary housing reduction with three internal planetary gears, ratio  $i = 5$ . Worm Center Distance 1.024 inches. CARO bronze gear ring with 120-160 HB hardness. Hardened steel worm with ground threads rotating on ball and roller bearings. Lubricated with synthetic oil. High temperature oil seals. 9 reduction gear ratios (i) are available from 37.5 to 400. Maximum rated torque 208.0 in-lbs. Versions B3 and B5. B5/S Left Version – B5/D Right Version.

## MOTORREDUCTOR DE TORNILLOS SIN FIN CON REDUCTOR EPICICLOIDAL

**MOTOR MP:** de corriente continua con imanes permanentes, en forma cerrada con ventilación externa. Aislamiento clase F. Alimentación con 12 ó 24 Vdc. Potencia absorbida 60 W. Protección IP 65 según normas CEI EN 60529.

**MOTOR MP3N-MP4N:** de corriente continua con imanes permanentes, en forma cerrada sin ventilación externa. Aislamiento clase F. Alimentación con 12 ó 24 Vdc. Potencia máx. absorbida 230 W. Protección IP 65 según normas CEI EN 60529.

**REDUCTOR:** con carcasa de aluminio inyectado a presión en la primera etapa de reducción con tornillo sin fin, y de acero en la segunda etapa de reducción de tipo epicicloidal con tres satélites internos. Corona de bronce CARO, dureza 120÷160 HB. Tornillo de acero templado con filete rectificado que gira sobre cojinetes de bolas. Lubricación con aceite especial de larga duración. Retenes de estanqueidad de goma especial para altas temperaturas. Las relaciones de reducción disponibles (i) son 9, de 37.5 a 400. Par nominal 208.0 in-lbs. Versión B3 ó B5. B5/S izquierdo - B5/D derecho.



Type	Ratio	Absorbed power	Delivered power	Input r.p.m.	Output r.p.m.	Rated torque	Voltage	Current
Tipo	Relación	Potencia absorbida	Potencia entregada	Revoluciones entrada	Revoluciones salida	Par nominal	Tensión	Intensidad
	i	W	HP	rpm	rpm	in-lbs	V	A
MCCE 12MP	37.5	60	1/20	2800	74	24.8	12	5
MCCE 24MP	37.5	60	1/20	2800	74	24.8	24	2.5
MCCE 12MP3N	37.5	115	1/10	2800	74	69.9	12	9.6
MCCE 12MP4N	37.5	230	1/5	2800	74	139.8	12	19.2
MCCE 24MP3N	37.5	115	1/10	2800	74	69.9	24	4.8
MCCE 24MP4N	37.5	230	1/5	2800	74	139.8	24	9.6
MCCE 12MP	50	60	1/20	2800	56	32.7	12	5
MCCE 24MP	50	60	1/20	2800	56	32.7	24	2.5
MCCE 12MP3N	50	115	1/10	2800	56	94.7	12	9.6
MCCE 12MP4N	50	230	1/5	2800	56	189.4	12	19.2
MCCE 24MP3N	50	115	1/10	2800	56	94.7	24	4.8
MCCE 24MP4N	50	230	1/5	2800	56	189.4	24	9.6
MCCE 12MP	75	60	1/20	2800	37	45.1	12	5
MCCE 24MP	75	60	1/20	2800	37	45.1	24	2.5
MCCE 12MP3N	75	115	1/10	2800	37	136.3	12	9.6
MCCE 24MP3N	75	115	1/10	2800	37	136.3	24	4.8
MCCE 12MP	100	60	1/20	2800	28	57.5	12	5
MCCE 24MP	100	60	1/20	2800	28	57.5	24	2.5
MCCE 12MP3N	100	115	1/10	2800	28	169.0	12	9.6
MCCE 24MP3N	100	115	1/10	2800	28	169.0	24	4.8
MCCE 12MP	150	60	1/20	2800	18.6	82.3	12	5
MCCE 24MP	150	60	1/20	2800	18.6	82.3	24	2.5
MCCE 12MP3N	150	108	1/11	2850	19	208.0	12	9
MCCE 24MP3N	150	108	1/11	2850	19	208.0	24	4.5
MCCE 12MP	200	60	1/20	2800	14	102.7	12	5
MCCE 24MP	200	60	1/20	2800	14	102.7	24	2.5
MCCE 12MP3N	200	84	1/14	2900	14.5	208.0	12	7
MCCE 24MP3N	200	84	1/14	2900	14.5	208.0	24	3.5
MCCE 12MP	300	60	1/20	2800	9.3	144.3	12	5
MCCE 24MP	300	60	1/20	2800	9.3	144.3	24	2.5
MCCE 12MP3N	300	79	1/15	2950	9.8	208.0	12	6.6
MCCE 24MP3N	300	79	1/15	2950	9.8	208.0	24	3.3
MCCE 12MP	350	60	1/20	2800	8	153.1	12	5
MCCE 24MP	350	60	1/20	2800	8	153.1	24	2.5
MCCE 12MP3N	350	72	1/16	3000	8.5	208.0	12	6
MCCE 24MP3N	350	72	1/16	3000	8.5	208.0	24	3
MCCE 12MP	400	60	1/20	2800	7	164.6	12	5
MCCE 24MP	400	60	1/20	2800	7	164.6	24	2.5
MCCE 12MP3N	400	69	1/18	3050	7.6	208.0	12	5.8
MCCE 24MP3N	400	69	1/18	3050	7.6	208.0	24	2.9



# MCCE

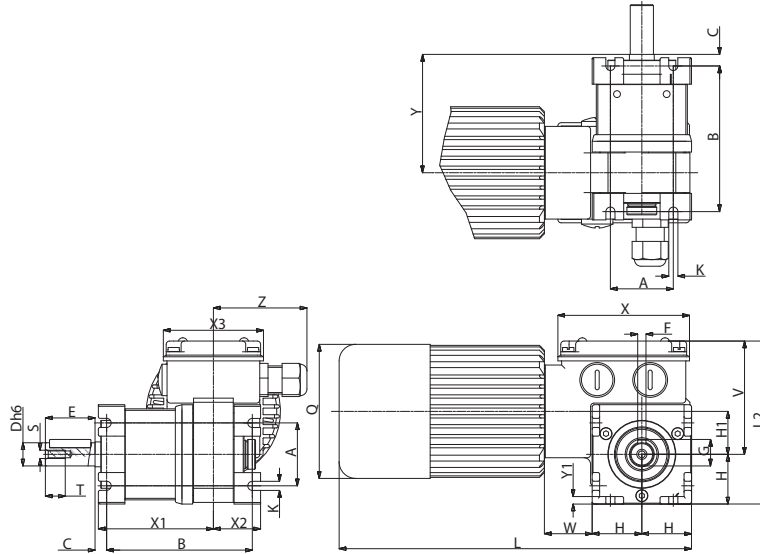

## B3/S

Type Tipo	A	B	C	D	E	F	G	H	H1	K	L	L1	Q
MCCE...MP	1.496	0.039	0.276	0.551	1.181	0.197	0.623	1.181	1.024	0.217	7.205	3.898	3.189

Type Tipo	S	T	V	W	X	X1	X2	X3	Y	Y1	Z	Weight Peso lbs
MCCE...MP	M5	0.394	2.717	1.102	3.150	2.756	1.142	2.362	2.953	0.236	2.205	5.36

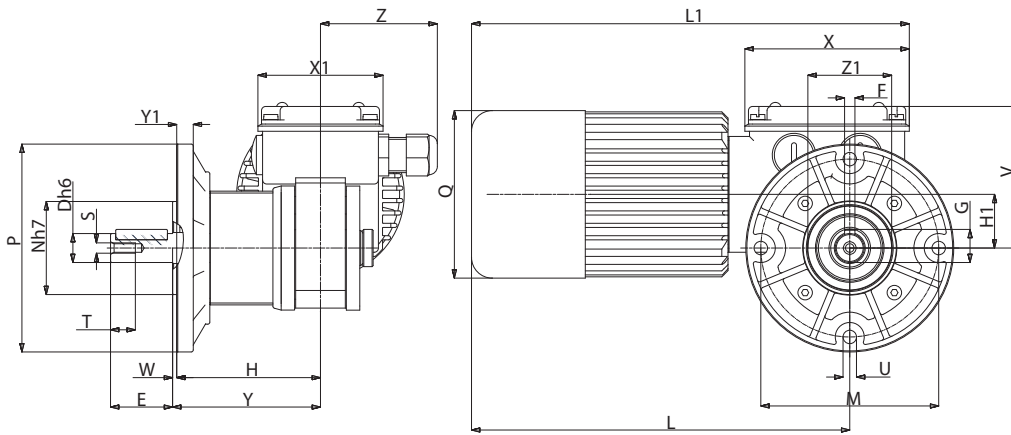

## B5/S

Type Tipo	D	E	F	G	H	H1	L	L1	M	N	P	Q
MCCE...MP	0.551	1.181	0.197	0.623	2.874	1.024	6.024	7.126	3.386	1.772	3.937	3.189

Type Tipo	S	T	U	V	W	X	X1	Y	Y1	Z	Z1	Weight Peso lbs
MCCE...MP	M5	0.394	0.256	2.717	0.079	3.150	2.362	2.953	0.315	2.205	1.575	5.52

For the self-braking version, add the letter KB to the type designation. Dimensions L, L1, increase by 1.063 in.

En la versión freno, añadir las letras KB a la sigla del tipo. Las cotas L, L1 aumentan de 1.063 in.

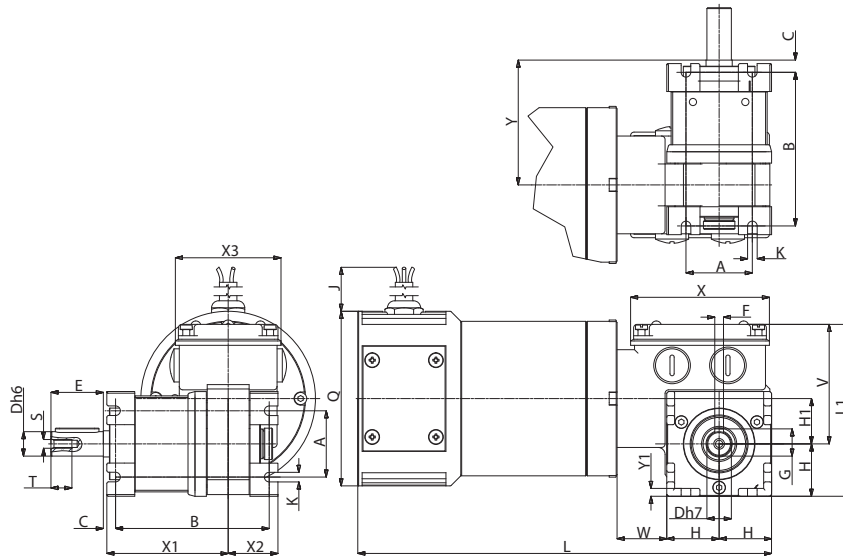

## B3/S

Type Tipo	A	B	C	D	E	F	G	H	H1	J	K	L	L1
MCCE...MP3N	1.496	3.465	0.276	0.551	1.181	0.197	0.630	1.181	1.024	20.472	0.217	9.252	3.898
MCCE...MP4N	1.496	3.465	0.276	0.551	1.181	0.197	0.630	1.181	1.024	20.472	0.217	11.220	3.898

Type Tipo	Q	S	T	V	W	X	X1	X2	X3	Y	Y1	Weight Peso lbs
MCCE...MP3N	3.937	M5	0.394	2.717	1.102	3.150	2.756	1.142	2.362	2.835	0.236	11.00
MCCE...MP4N	3.937	M5	0.394	2.717	1.102	3.150	2.756	1.142	2.362	2.835	0.236	15.20

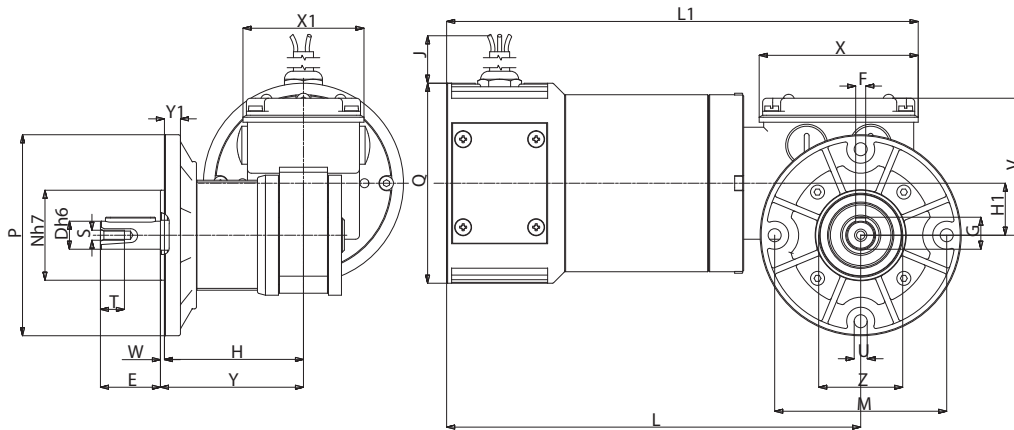

## B5/S

Type Tipo	D	E	F	G	H	H1	J	L	L1	M	N	P
MCCE...MP3N	0.551	1.181	0.197	0.630	2.717	1.024	20.472	8.071	9.213	3.386	1.772	3.937
MCCE...MP4N	0.551	1.181	0.197	0.630	2.717	1.024	20.472	10.039	11.181	3.386	1.772	3.937

Type Tipo	Q	S	T	U	V	W	X	X1	Y	Y1	Z	Weight Peso lbs
MCCE...MP3N	3.937	M5	0.394	0.256	2.717	0.079	3.150	2.362	2.795	0.315	1.575	11.17
MCCE...MP4N	3.937	M5	0.394	0.256	2.717	0.079	3.150	2.362	2.795	0.315	1.575	15.37