



N.B. For the correct choice of the gearmotor, please refer to the tables on page 118. Refer to AM series page 12 for motor revs under load. These geared motors require a running-in period. Therefore, during the first 30 working hours, the resulting torque will be lower than the values given. On request, motor can be supplied with electromagnetic brake at 230 Vac, marked with letter KA(MCEKA), see specifications on page 120.

N.B. Para una selección correcta del motorreductor se aconseja ajustarse a las tablas presentadas en la página 118. Para las revoluciones motor bajo carga hágase referencia a la serie AM en la página 12. Estos motorreductores necesitan un cierto rodaje. Por lo tanto, en las primeras 30 horas de funcionamiento, se notará un par menor que los datos presentados. A petición es posible suministrar el motor con freno electromagnético alimentado con 230 Vac, que se distingue por la letra KA (MCEKA), ver características en la pág. 120.

WORM GEAR MOTOR WITH PLANETARY REDUCTION GEAR

MOTOR: Asynchronous single or three phase with 2 or 4 poles, totally enclosed with external ventilation. Thermal safety cutout on single phase models. Class F windings. IP65 protection according to CEI EN 60529.

GEAR UNIT: With die-cast aluminum worm housing reduction and steel planetary housing reduction with three internal planetary gears, ratio $i = 5$. Worm Center Distance 1.024 inches. CARO bronze gear ring with 120-160 HB hardness. Hardened steel worm with ground threads rotating on ball and roller bearings. Lubricated with synthetic oil. High temperature oil seals. 9 reduction gear ratios (i) are available from 37.5 to 400. Maximum rated torque 208.0 in-lbs. Versions B3 and B5. B5/S Left Version – B5/D Right Version.

MOTORREDUCTOR DE TORNILLOS SIN FIN CON REDUCTOR EPICICLOIDAL

MOTOR: asíncrono monofásico o trifásico de 2 ó 4 polos, en forma cerrada con ventilación externa. Protector térmico de seguridad en el tipo monofásico. Aislamiento clase F. Protección IP 65 según normas CEI EN 60529.

REDUCTOR: con carcasa de aluminio inyectado a presión en la primera etapa de reducción con tornillo sin fin, y de acero en la segunda etapa de reducción de tipo epicicloidal con tres satélites internos. Corona de bronce CARO, dureza 120÷160 HB. Tornillo de acero templado con filete rectificad que gira sobre cojinetes de bolas. Lubricación con aceite especial de larga duración. Retenes de estanqueidad de goma especial para altas temperaturas. Las relaciones de reducción disponibles (i) son 9, de 37.5 a 400. Par nominal 208.0 in-lbs. Versión B3 ó B5. B5/S izquierdo - B5/D derecho.



MCE

Type	Ratio	Delivered power	Input r.p.m. no-load	Output r.p.m. no-load	Rated torque	Voltage	Current	Capacitor
Tipo	Relación	Potencia entregada	Revoluciones entrada sin carga	Revoluciones salida sin carga	Par nominal	Tensión	Intensidad	Condensador
	i	HP	rpm	rpm	in-lbs	Vac - 60 Hz	A	µF
MCE 100P	37.5	1/18	3360	90	33.6	115 1Ø	0.98	12.5
MCE 160P2	37.5	1/10	3360	90	62.8	115 1Ø	1.30	16
MCE 240P3	37.5	1/5	3360	90	145.1	115 1Ø	2.47	32
MCE 80P	37.5	1/40	1680	45	33.6	115 1Ø	0.80	16
MCE 110P2	37.5	1/33	1680	45	42.5	115 1Ø	1	20
MCE 165P3	37.5	1/14	1680	45	99.1	115 1Ø	1.28	16
MCE 244PT	37.5	1/13	3360	90	51.3	230 3Ø	0.62	-
MCE 320P2T	37.5	1/9	3360	90	77.0	230 3Ø	0.74	-
MCE 440P3T	37.5	1/4	3360	90	188.5	230 3Ø	1.08	-
MCE 110PT	37.5	1/40	1680	45	30.1	230 3Ø	0.30	-
MCE 145P2T	37.5	1/33	1680	45	38.9	230 3Ø	0.38	-
MCE 230P3T	37.5	1/10	1680	45	145.1	230 3Ø	0.70	-
MCE 100P	50	1/18	3360	67	46.9	115 1Ø	0.98	12.5
MCE 160P2	50	1/10	3360	67	81.4	115 1Ø	1.30	16
MCE 240P3	50	1/5	3360	67	187.6	115 1Ø	2.47	32
MCE 80P	50	1/40	1680	33	42.5	115 1Ø	0.80	16
MCE 110P2	50	1/33	1680	33	55.8	115 1Ø	1	20
MCE 165P3	50	1/14	1680	33	132.8	115 1Ø	1.28	16
MCE 244PT	50	1/13	3360	67	68.1	230 3Ø	0.62	-
MCE 320P2T	50	1/9	3360	67	102.7	230 3Ø	0.74	-
MCE 440P3T	50	1/4	3360	67	*208.0	230 3Ø	1.08	-
MCE 110PT	50	1/40	1680	33	38.9	230 3Ø	0.30	-
MCE 145P2T	50	1/33	1680	33	51.3	230 3Ø	0.38	-
MCE 230P3T	50	1/10	1680	33	188.5	230 3Ø	0.70	-
MCE 100P	75	1/18	3360	45	68.1	115 1Ø	0.98	12.5
MCE 160P2	75	1/10	3360	45	119.5	115 1Ø	1.30	16
MCE 240P3	75	1/5	3360	45	*208.0	115 1Ø	2.47	32
MCE 80P	75	1/40	1680	22	63.7	115 1Ø	0.80	16
MCE 110P2	75	1/33	1680	22	81.4	115 1Ø	1	20
MCE 165P3	75	1/14	1680	22	192.9	115 1Ø	1.28	16
MCE 244PT	75	1/13	3360	45	98.2	230 3Ø	0.62	-
MCE 320P2T	75	1/9	3360	45	145.1	230 3Ø	0.74	-
MCE 440P3T	75	1/4	3360	45	*208.0	230 3Ø	1.08	-
MCE 110PT	75	1/40	1680	22	60.2	230 3Ø	0.30	-
MCE 145P2T	75	1/33	1680	22	77.0	230 3Ø	0.38	-
MCE 230P3T	75	1/10	1680	22	*208.0	230 3Ø	0.70	-

(*) - Under no circumstances should the torque values marked with an asterisk be exceeded. With the higher gear ratios the motor power is considerably higher than the capacity of the gear unit.

(*) - Los valores referentes al par marcados con el asterisco, no se deben en absoluto superar, ya que, con las altas relaciones, la potencia del motor es notablemente mayor que la capacidad del reductor.



Type	Ratio	Delivered power	Input r.p.m. no-load	Output r.p.m. no-load	Rated torque	Voltage	Current	Capacitor
Tipo	Relación	Potencia entregada	Revoluciones entrada sin carga	Revoluciones salida sin carga	Par nominal	Tensión	Intensidad	Condensador
	i	HP	rpm	rpm	in lbs	Vac - 60 Hz	A	µF
MCE 100P	100	1/18	3360	33	101.8	115 1Ø	0.98	12.5
MCE 160P2	100	1/10	3360	33	145.1	115 1Ø	1.30	16
MCE 240P3	100	1/5	3360	33	*208.0	115 1Ø	2.47	32
MCE 80P	100	1/40	1680	17	77.0	115 1Ø	0.80	16
MCE 110P2	100	1/33	1680	17	98.2	115 1Ø	1	20
MCE 165P3	100	1/14	1680	17	*208.0	115 1Ø	1.28	16
MCE 244PT	100	1/13	3360	33	119.5	230 3Ø	0.62	-
MCE 320P2T	100	1/9	3360	33	179.7	230 3Ø	0.74	-
MCE 440P3T	100	1/4	3360	33	*208.0	230 3Ø	1.08	-
MCE 110PT	100	1/40	1680	17	72.6	230 3Ø	0.30	-
MCE 145P2T	100	1/33	1680	17	93.8	230 3Ø	0.38	-
MCE 230P3T	100	1/10	1680	17	*208.0	230 3Ø	0.70	-
MCE 100P	150	1/18	3360	22	119.5	115 1Ø	0.98	12.5
MCE 160P2	150	1/10	3360	22	205.3	115 1Ø	1.30	16
MCE 80P	150	1/40	1680	11	111.5	115 1Ø	0.80	16
MCE 110P2	150	1/33	1680	11	137.2	115 1Ø	1	20
MCE 165P3	150	1/14	1680	11	*208.0	115 1Ø	1.28	16
MCE 244PT	150	1/13	3360	22	166.4	230 3Ø	0.62	-
MCE 320P2T	150	1/9	3360	22	*208.0	230 3Ø	0.74	-
MCE 110PT	150	1/40	1680	11	102.7	230 3Ø	0.30	-
MCE 145P2T	150	1/33	1680	11	128.3	230 3Ø	0.38	-
MCE 100P	200	1/18	3360	17	150.4	115 1Ø	0.98	12.5
MCE 160P2	200	1/10	3360	17	*208.0	115 1Ø	1.30	16
MCE 80P	200	1/40	1680	8	137.2	115 1Ø	0.80	16
MCE 110P2	200	1/33	1680	8	170.8	115 1Ø	1	20
MCE 165P3	200	1/14	1680	8	*208.0	115 1Ø	1.28	16
MCE 244PT	200	1/13	3360	17	205.3	230 3Ø	0.62	-
MCE 320P2T	200	1/9	3360	17	*208.0	230 3Ø	0.74	-
MCE 110PT	200	1/40	1680	8	128.3	230 3Ø	0.30	-
MCE 145P2T	200	1/33	1680	8	162.0	230 3Ø	0.38	-
MCE 100P	300	1/18	3360	11	*208.0	115 1Ø	0.98	12.5
MCE 80P	300	1/40	1680	6	196.5	115 1Ø	0.80	16
MCE 110P2	300	1/33	1680	6	*208.0	115 1Ø	1	20
MCE 244PT	300	1/13	3360	11	*208.0	230 3Ø	0.62	-
MCE 110PT	300	1/40	1680	6	179.7	230 3Ø	0.30	-
MCE 145P2T	300	1/33	1680	6	*208.0	230 3Ø	0.38	-



MCE

Type	Ratio	Delivered power	Input r.p.m. no-load	Output r.p.m. no-load	Rated torque	Voltage	Current	Capacitor
Tipo	Relación	Potencia entregada	Revoluciones entrada sin carga	Revoluciones salida sin carga	Par nominal	Tensión	Intensidad	Condensador
	i	HP	rpm	rpm	in-lbs	Vac - 60 Hz	A	µF
MCE 100P	350	1/18	3360	10	*208.0	115 1Ø	0.98	12.5
MCE 80P	350	1/40	1680	5	*208.0	115 1Ø	0.80	16
MCE 244PT	350	1/13	3360	10	*208.0	230 3Ø	0.62	-
MCE 110PT	350	1/40	1680	5	192.0	230 3Ø	0.30	-
MCE 100P	400	1/18	3360	8	*208.0	115 1Ø	0.98	12.5
MCE 80P	400	1/40	1680	4	*208.0	115 1Ø	0.80	16
MCE 244PT	400	1/13	3360	8	*208.0	230 3Ø	0.62	-
MCE 110PT	400	1/40	1680	4	*208.0	230 3Ø	0.30	-

(*) - Under no circumstances should the torque values marked with an asterisk be exceeded. With the higher gear ratios the motor power is considerably higher than the capacity of the gear unit.

(*) - Los valores referentes al par marcados con el asterisco, no se deben en absoluto superar, ya que, con las altas relaciones, la potencia del motor es notablemente mayor que la capacidad del reductor.

Also available in 230 Vac single phase input.
 Also available in 460 Vac three phase input.
 Note - 230 Vac three phase suitable at 208 Vac.

Disponible también con entrada monofásica de 230 Vca.
 Disponible también con entrada trifásica de 460 Vca.
 Nota - 230 Vca trifásica adecuada para 208 Vca.

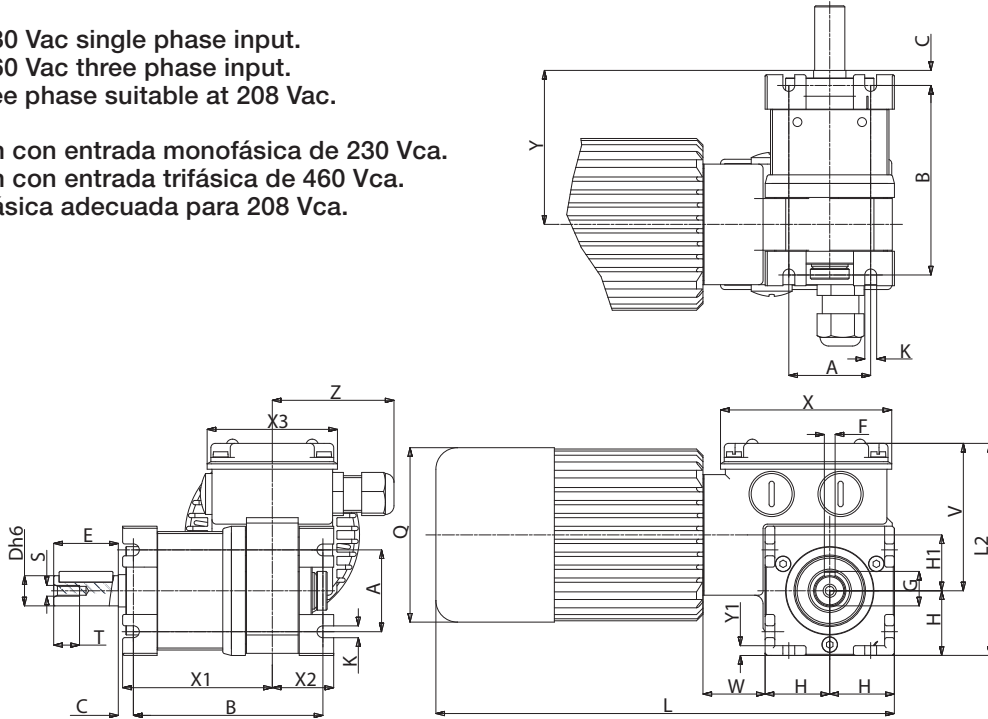

B3/S

Type Tipo	A	B	C	D	E	F	G	H	H1	K	L	L1	Q
MCE...P	1.496	3.465	0.276	0.551	1.181	0.197	0.630	1.181	1.024	0.217	7.598	3.898	3.189
MCE...P2	1.496	3.465	0.276	0.551	1.181	0.197	0.630	1.181	1.024	0.217	8.386	3.898	3.189
MCE...P3	1.496	3.465	0.276	0.551	1.181	0.197	0.630	1.181	1.024	0.217	9.882	3.898	3.740

Type Tipo	S	T	V	W	X	X1	X2	X3	Y	Y1	Z	Weight Peso lbs
MCE...P	M5	0.394	2.717	1.102	3.150	2.756	1.142	2.362	2.835	0.236	2.205	6.54
MCE...P2	M5	0.394	2.717	1.102	3.150	2.756	1.142	2.362	2.835	0.236	2.205	7.22
MCE...P3	M5	0.394	2.717	1.102	3.150	2.756	1.142	2.362	2.835	0.236	2.205	9.62

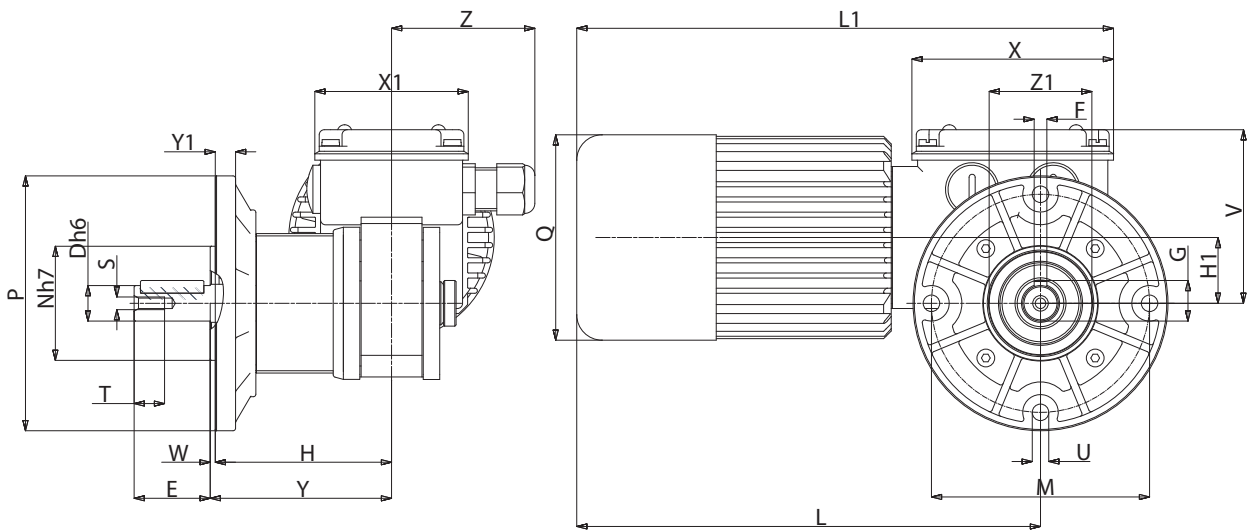

B5/S

Type Tipo	D	E	F	G	H	H1	L	L1	M	N	P	Q
MCE...P	0.551	1.181	0.197	0.630	2.717	1.024	6.417	7.520	3.386	1.772	3.937	3.189
MCE...P2	0.551	1.181	0.197	0.630	2.717	1.024	7.205	8.307	3.386	1.772	3.937	3.189
MCE...P3	0.551	1.181	0.197	0.630	2.717	1.024	8.701	9.803	3.386	1.772	3.937	3.189

Type Tipo	S	T	U	V	W	X	X1	Y	Y1	Z	Z1	Weight Peso lbs
MCE...P	M5	0.394	0.256	2.717	0.079	3.150	2.362	2.795	0.315	2.205	1.575	6.70
MCE...P2	M5	0.394	0.256	2.717	0.079	3.150	2.362	2.795	0.315	2.205	1.575	7.39
MCE...P3	M5	0.394	0.256	2.717	0.079	3.150	2.362	2.795	0.315	2.205	1.575	9.79

For the self-braking version, add the letter KA to the type designation. Dimensions L, L1, increase by 1.063 in.

En la versión freno, añadir la letra KA a la sigla del tipo. Las cotas L, L1 aumentan de 1.063 in.