



N.B. For the correct choice of the gearmotor, please refer to the tables on page 118. Refer to AM series page 12 for motor revs under load. On request, motor may be supplied with electromagnetic brake at 230 Vac, marked with letter KA (PAKA), or at 24 Vdc, marked with letter KB (PAKB), see specifications on page 120.

N.B. Para una selección correcta del motorreductor se aconseja ajustarse a las tablas presentadas en la página 118. Para las revoluciones motor bajo carga hágase referencia a la serie AM pág. 12. A petición es posible proporcionar el motor con freno electromagnético alimentado con 230 Vca. que se distingue por la letra KA (PAKA) ó 24Vdc. que se distingue por las letras KB (PAKB). ver características en la pág. 120.

COAXIAL GEARED MOTOR

MOTOR: Asynchronous single or three phase with 2 or 4 poles, totally enclosed with external ventilation. Thermal safety cutout on single phase models. Class F windings. IP65 protection according to CEI EN 60529.

GEAR UNIT: With die-cast aluminum housing. Case-hardened gearing with shafts rotating on roller bearings. Lubricated with synthetic oil. High temperature oil seals. 14 gear ratios (i) from 6.48 to 372.8. Rated torque 177 in-lbs. Versions B3 or B5.

MOTORREDUCTOR COAXIAL DE ENGRANAJES

MOTOR: *asíncrono monofásico o trifásico de 2 ó 4 polos, en forma cerrada con ventilación externa. Protector térmico de seguridad en el tipo monofásico. Aislamiento clase F. Protección IP 65 según normas CEI EN 60529.*

REDUCTOR: *con carcasa de aluminio inyectado a presión. Engranajes templados y endurecidos con correspondientes ejes que giran sobre cojinetes de rodillos. Lubricación con aceite especial de larga duración. Retenes para la estanqueidad de goma especial para altas temperaturas. Las relaciones de reducción disponibles (i) son 14, de 6.48 a 372.8. Par nominal 177 in-lbs. Versión B3 ó B5.*

PA



Type Tipo	Ratio Relación	Delivered power Potencia entregada	Input r.p.m. no-load Revoluciones entrada sin carga	Output r.p.m. no-load Revoluciones salida sin carga	Rated torque Par nominal	Voltage Tensión	Current Intensidad	Capacitor Condensador
	i	HP	rpm	rpm	in-lbs	Vac - 60 Hz	A	µF
PA 180M2	6.48	1/8	3360	518	11.5	115 1Ø	1.63	20
PA 240M3	6.48	1/5	3360	518	23.0	115 1Ø	2.47	32
PA 130M2	6.48	1/18	1680	259	9.7	115 1Ø	1.08	12.5
PA 165M3	6.48	1/14	1680	259	15.9	115 1Ø	1.28	16
PA 260M2T	6.48	1/8	3360	518	11.5	230 3Ø	0.6	-
PA 440M3T	6.48	1/4	3360	518	31.0	230 3Ø	1.08	-
PA 140M2T	6.48	1/16	1680	259	13.3	230 3Ø	0.4	-
PA 230M3T	6.48	1/10	1680	259	24.8	230 3Ø	0.7	-
PA 180M2	10.27	1/8	3360	326	17.7	115 1Ø	1.63	20
PA 240M3	10.27	1/5	3360	326	36.3	115 1Ø	2.47	32
PA 130M2	10.27	1/18	1680	163	15.9	115 1Ø	1.08	12.5
PA 165M3	10.27	1/14	1680	163	25.7	115 1Ø	1.28	16
PA 260M2T	10.27	1/8	3360	326	17.7	230 3Ø	0.6	-
PA 440M3T	10.27	1/4	3360	326	49.6	230 3Ø	1.08	-
PA 140M2T	10.27	1/16	1680	163	21.2	230 3Ø	0.4	-
PA 230M3T	10.27	1/10	1680	163	38.9	230 3Ø	0.7	-
PA 180M2	14.12	1/8	3360	236	24.8	115 1Ø	1.63	20
PA 240M3	14.12	1/5	3360	236	49.6	115 1Ø	2.47	32
PA 130M2	14.12	1/18	1680	118	21.2	115 1Ø	1.08	12.5
PA 165M3	14.12	1/14	1680	118	35.4	115 1Ø	1.28	16
PA 260M2T	14.12	1/8	3360	236	24.8	230 3Ø	0.6	-
PA 440M3T	14.12	1/4	3360	236	68.1	230 3Ø	1.08	-
PA 140M2T	14.12	1/16	1680	118	30.1	230 3Ø	0.4	-
PA 230M3T	14.12	1/10	1680	118	54.0	230 3Ø	0.7	-
PA 180M2	17.6	1/8	3360	191	31.0	115 1Ø	1.63	20
PA 240M3	17.6	1/5	3360	191	62.0	115 1Ø	2.47	32
PA 130M2	17.6	1/18	1680	95.5	27.4	115 1Ø	1.08	12.5
PA 165M3	17.6	1/14	1680	95.5	43.4	115 1Ø	1.28	16
PA 260M2T	17.6	1/8	3360	191	31.0	230 3Ø	0.6	-
PA 440M3T	17.6	1/4	3360	191	85.8	230 3Ø	1.08	-
PA 140M2T	17.6	1/16	1680	95.5	35.4	230 3Ø	0.4	-
PA 230M3T	17.6	1/10	1680	95.5	66.4	230 3Ø	0.7	-
PA 180M2	25.21	1/8	3360	133	44.3	115 1Ø	1.63	20
PA 240M3	25.21	1/5	3360	133	88.5	115 1Ø	2.47	32
PA 130M2	25.21	1/18	1680	66.5	39.8	115 1Ø	1.08	12.5
PA 165M3	25.21	1/14	1680	66.5	62.0	115 1Ø	1.28	16
PA 260M2T	25.21	1/8	3360	133	44.3	230 3Ø	0.6	-
PA 440M3T	25.21	1/4	3360	133	122.1	230 3Ø	1.08	-
PA 140M2T	25.21	1/16	1680	66.5	51.3	230 3Ø	0.4	-
PA 230M3T	25.21	1/10	1680	66.5	95.6	230 3Ø	0.7	-
PA 180M2	34.66	1/8	3360	96.8	61.1	115 1Ø	1.63	20
PA 240M3	34.66	1/5	3360	96.8	122.1	115 1Ø	2.47	32
PA 130M2	34.66	1/18	1680	48.4	54.9	115 1Ø	1.08	12.5
PA 165M3	34.66	1/14	1680	48.4	85.8	115 1Ø	1.28	16
PA 260M2T	34.66	1/8	3360	96.8	61.1	230 3Ø	0.6	-
PA 440M3T	34.66	1/4	3360	96.8	168.2	230 3Ø	1.08	-
PA 140M2T	34.66	1/16	1680	48.4	70.8	230 3Ø	0.4	-
PA 230M3T	34.66	1/10	1680	48.4	131.9	230 3Ø	0.7	-



PA

Type Tipo	Ratio Relación	Delivered power Potencia entregada	Input r.p.m. no-load Revoluciones entrada sin carga	Output r.p.m. no-load Revoluciones salida sin carga	Rated torque Par nominal	Voltage Tensión	Current Intensidad	Capacitor Condensador
	i	HP	rpm	rpm	in-lbs	Vac - 60 Hz	A	µF
PA 180M2	43.21	1/8	3360	77.6	76.1	115 1Ø	1.63	20
PA 240M3	43.21	1/5	3360	77.6	153.1	115 1Ø	2.47	32
PA 130M2	43.21	1/18	1680	38.8	68.1	115 1Ø	1.08	12.5
PA 165M3	43.21	1/14	1680	38.8	106.2	115 1Ø	1.28	16
PA 260M2T	43.21	1/8	3360	77.6	76.1	230 3Ø	0.6	-
PA 440M3T	43.21	1/4	3360	77.6	*177.0	230 3Ø	1.08	-
PA 140M2T	43.21	1/16	1680	38.8	87.6	230 3Ø	0.4	-
PA 230M3T	43.21	1/10	1680	38.8	164.6	230 3Ø	0.7	-
PA 180M2	61.8	1/8	3360	54	108.9	115 1Ø	1.63	20
PA 240M3	61.8	1/5	3360	54	*177.0	115 1Ø	2.47	32
PA 130M2	61.8	1/18	1680	27	98.2	115 1Ø	1.08	12.5
PA 165M3	61.8	1/14	1680	27	153.1	115 1Ø	1.28	16
PA 260M2T	61.8	1/8	3360	54	108.9	230 3Ø	0.6	-
PA 440M3T	61.8	1/4	3360	54	*177.0	230 3Ø	1.08	-
PA 140M2T	61.8	1/16	1680	27	125.7	230 3Ø	0.4	-
PA 230M3T	61.8	1/10	1680	27	*177.0	230 3Ø	0.7	-
PA 180M2	85	1/8	3360	39.4	149.6	115 1Ø	1.63	20
PA 240M3	85	1/5	3360	39.4	*177.0	115 1Ø	2.47	32
PA 130M2	85	1/18	1680	19.7	135.4	115 1Ø	1.08	12.5
PA 165M3	85	1/14	1680	19.7	*177.0	115 1Ø	1.28	16
PA 260M2T	85	1/8	3360	39.4	149.6	230 3Ø	0.6	-
PA 440M3T	85	1/4	3360	39.4	*177.0	230 3Ø	1.08	-
PA 140M2T	85	1/16	1680	19.7	173.5	230 3Ø	0.4	-
PA 230M3T	85	1/10	1680	19.7	*177.0	230 3Ø	0.7	-
PA 180M2	106	1/8	3360	31.7	*177.0	115 1Ø	1.63	20
PA 130M2	106	1/18	1680	15.8	169.0	115 1Ø	1.08	12.5
PA 260M2T	106	1/8	3360	31.7	*177.0	230 3Ø	0.6	-
PA 140M2T	106	1/16	1680	15.8	*177.0	230 3Ø	0.4	-
PA 180M2	151.8	1/8	3360	22.0	*177.0	115 1Ø	1.63	20
PA 130M2	151.8	1/18	1680	11.0	*177.0	115 1Ø	1.08	12.5
PA 260M2T	151.8	1/8	3360	22.0	*177.0	230 3Ø	0.6	-
PA 140M2T	151.8	1/16	1680	11.0	*177.0	230 3Ø	0.4	-
PA 180M2	208.8	1/8	3360	16.0	*177.0	115 1Ø	1.63	20
PA 130M2	208.8	1/18	1680	8.0	*177.0	115 1Ø	1.08	12.5
PA 260M2T	208.8	1/8	3360	16.0	*177.0	230 3Ø	0.6	-
PA 140M2T	208.8	1/16	1680	8.0	*177.0	230 3Ø	0.4	-



Type Tipo	Ratio Relación	Delivered power Potencia entregada	Input r.p.m. no-load Revoluciones entrada sin carga	Output r.p.m. no-load Revoluciones salida sin carga	Rated torque Par nominal	Voltage Tensión	Current Intensidad	Capacitor Condensador
	i	HP	rpm	rpm	in-lbs	Vac - 60 Hz	A	µF
PA 180M2	260.3	1/8	3360	12.8	*177.0	115 1Ø	1.63	20
PA 130M2	260.3	1/18	1680	6.4	*177.0	115 1Ø	1.08	12.5
PA 260M2T	260.3	1/8	3360	12.8	*177.0	230 3Ø	0.6	-
PA 140M2T	260.3	1/16	1680	6.4	*177.0	230 3Ø	0.4	-
PA 180M2	372.8	1/8	3360	9	*177.0	115 1Ø	1.63	20
PA 130M2	372.8	1/18	1680	4.5	*177.0	115 1Ø	1.08	12.5
PA 260M2T	372.8	1/8	3360	9	*177.0	230 3Ø	0.6	-
PA 140M2T	372.8	1/16	1680	4.5	*177.0	230 3Ø	0.4	-

(*) - Under no circumstances should the torque values marked with an asterisk be exceeded. With the higher gear ratios the motor power is considerably higher than the capacity of the gear unit.

(*) - Los valores referentes al par marcados con el asterisco, no se deben en absoluto superar, ya que, con las altas relaciones, la potencia del motor es notablemente mayor que la capacidad del reductor.

Also available in 230 Vac single phase input.
Also available in 460 Vac three phase input.

Note - 230 Vac three phase suitable at 208 Vac.

Disponible también con entrada monofásica de 230 Vca.
Disponible también con entrada trifásica de 460 Vca.
Nota - 230 Vca trifásica adecuada para 208 Vca.

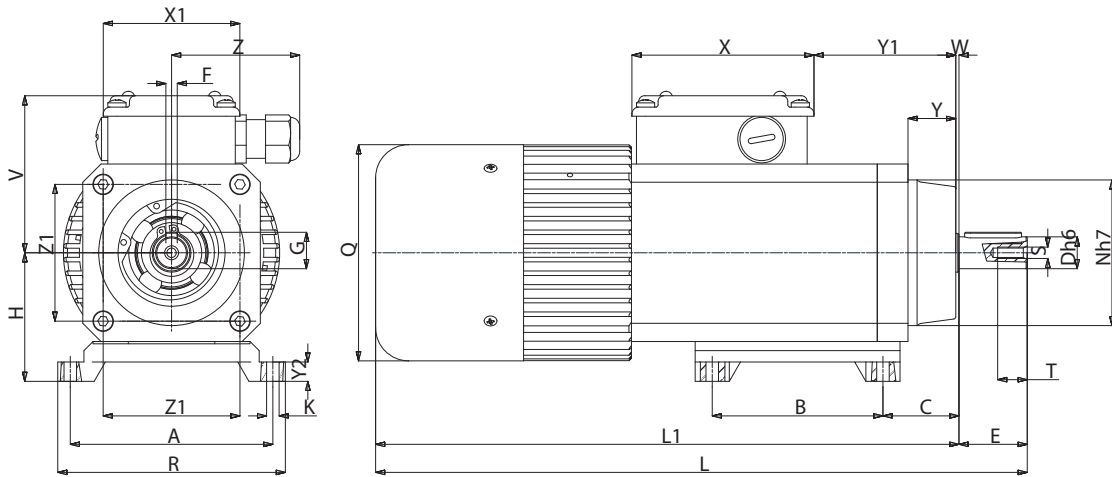

B3

Type Tipo	A	B	C	D	E	F	G	H	K	L	L1	N	Q
PA...M2	3.504	2.953	1.300	0.551	1.181	0.197	0.642	2.205	0.217	11.260	10.079	2.520	3.740
PA...M3	3.504	2.953	1.300	0.551	1.181	0.197	0.642	2.205	0.217	12.244	11.063	2.520	3.740

Type Tipo	R	S	T	V	X	X1	Y	Y1	Y2	W	Z	Z1	Weight Peso lbs
PA...M2	3.937	M5	0.512	2.795	3.150	2.362	0.827	2.520	0.354	0.059	2.205	2.362	9.305
PA...M3	3.937	M5	0.512	2.795	3.150	2.362	0.827	2.520	0.354	0.059	2.205	2.362	10.905



PA

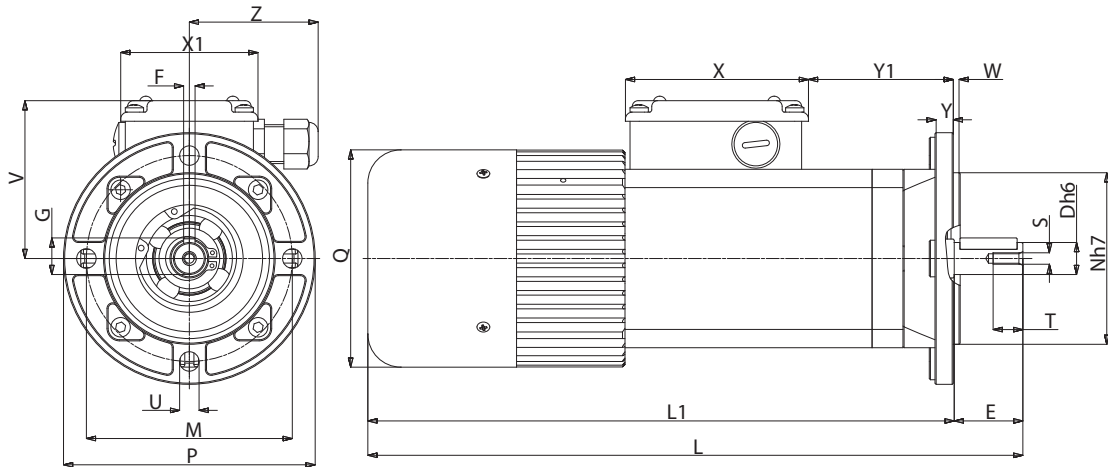

B5

Type Tipo	D	E	F	G	L	L1	M	N	P	Q	S
PA...M2	0.551	1.181	0.197	0.642	11.260	10.079	3.543	2.953	3.937	3.740	M5
PA...M3	0.551	1.181	0.197	0.642	12.244	11.063	3.543	2.953	3.937	3.740	M5

Type Tipo	T	U	V	X	X1	Y	Y1	W	Z	Weight Peso lbs
PA...M2	0.512	0.335	2.796	3.150	2.362	0.413	2.560	0.118	2.205	9.371
PA...M3	0.512	0.335	2.796	3.150	2.362	0.413	2.560	0.118	2.205	10.971

For the self-braking version, add the letter KA or KB to the type designation. Dimensions L, L1, increase by 0.984 in.

En la versión freno, añadir las letras KA ó KB a la sigla del tipo. Las cotas L, L1 aumentan de 0.984 in.