

**N.B.** For the correct choice of the gearmotor, please refer to the tables on page 119. Refer to AM series page 12 for motor revs under load. On request, motor may be supplied with electromagnetic brake at 230 Vac, marked with letter KA (PAEKA), or at 24 Vdc, marked with letter KB (PAEKB), see specifications on page 120.

**N.B.** Para una selección correcta del motorreductor se aconseja ajustarse a las tablas presentadas en la página 119. Para las revoluciones motor bajo carga hágase referencia a la serie AM pág. 12. A petición es posible proporcionar el motor con freno electromagnético alimentado con 230 Vca. que se distingue por la letra KA (PAEKA) ó 24Vdc. que se distingue por las letras KB (PAEKB), ver características en la pág. 120.

## COAXIAL GEARED MOTOR WITH PLANETARY REDUCTION GEAR

**MOTOR:** asynchronous single or three phase with 2 or 4 poles, totally enclosed with external ventilation. Thermal safety cutout on single phase model. Class F winding, IP65 protection according to CEI EN 60529.

**GEAR UNIT:** first stage with die-cast aluminium casing, second stage in steel. Case-hardened and hardened gear pairs with shafts rotating on roller bearings. Lubrication with long life oil. Sealing rings made in special rubber for high temperatures. 13 gear ratios (i) available, from 48.7 to 1770.9. Rated torque 796.5 in-lbs. Version B3 or B5.

## MOTORREDUCTOR COAXIAL DE ENGRANAJES CON REDUCTOR EPICICLOIDAL

**MOTOR:** asíncrono monofásico o trifásico de 2 ó 4 polos, en forma cerrada con ventilación externa. Protector térmico de seguridad en el tipo monofásico. Aislamiento clase F. Protección IP 65 según normas CEI EN 60529.

**REDUCTOR:** Primera etapa con carcasa de aluminio inyectado a presión, segunda etapa de acero. Engranajes templados y endurecidos con correspondientes ejes que giran sobre cojinetes de rodillos. Lubricación con aceite especial de larga duración. Retenes para la estanqueidad de goma especial para altas temperaturas. Las relaciones de reducción disponibles (i) son 13, de 48.7 a 1770.9. Par nominal 796.5 in-lbs. Versión B3 ó B5.



Type Tipo	Ratio Relación	Delivered power Potencia entregada	Input r.p.m. no-load Revoluciones entrada sin carga	Output r.p.m. no-load Revoluciones salida sin carga	Rated torque Par nominal	Voltage Tensión	Current Intensidad	Capacitor Condensador
	i	W	rpm	rpm	in-lbs	Vac - 60 Hz	A	µF
PAE 180M2	48.7	1/8	3360	68.8	79.6	230	0.82	5
PAE 240M3	48.7	1/5	3360	68.8	163.7	230	1.24	8
PAE 130M2	48.7	1/18	1680	34.2	71.7	230	0.54	3.15
PAE 165M3	48.7	1/14	1680	34.2	115	230	0.64	4
PAE 260M2T	48.7	1/8	3360	68.8	79.6	460 Y	0.29 Y	-
PAE 440M3T	48.7	1/4	3360	68.8	223.0	460 Y	0.52 Y	-
PAE 140M2T	48.7	1/16	1680	34.2	95.6	460 Y	0.19 Y	-
PAE 230M3T	48.7	1/10	1680	34.2	175.2	460 Y	0.34 Y	-
PAE 180M2	67	1/8	3360	49.8	111.5	230	0.82	5
PAE 240M3	67	1/5	3360	49.8	223.0	230	1.24	8
PAE 130M2	67	1/18	1680	24.8	95.6	230	0.54	3.15
PAE 165M3	67	1/14	1680	24.8	159.3	230	0.64	4
PAE 260M2T	67	1/8	3360	49.8	111.5	460 Y	0.29 Y	-
PAE 440M3T	67	1/4	3360	49.8	307.1	460 Y	0.52 Y	-
PAE 140M2T	67	1/16	1680	24.8	135.4	460 Y	0.19 Y	-
PAE 230M3T	67	1/10	1680	24.8	243.4	460 Y	0.34 Y	-
PAE 180M2	83.6	1/8	3360	39.6	139.8	230	0.82	5
PAE 240M3	83.6	1/5	3360	39.6	178.8	230	1.24	8
PAE 130M2	83.6	1/18	1680	19.8	123.9	230	0.54	3.15
PAE 165M3	83.6	1/14	1680	19.8	196.6	230	0.64	4
PAE 260M2T	83.6	1/8	3360	39.6	139.8	460 Y	0.29 Y	-
PAE 440M3T	83.6	1/4	3360	39.6	386.7	460 Y	0.52 Y	-
PAE 140M2T	83.6	1/16	1680	19.8	159.3	460 Y	0.19 Y	-
PAE 230M3T	83.6	1/10	1680	19.8	299.1	460 Y	0.34 Y	-
PAE180M2	119.7	1/8	3360	27.6	199.1	230	0.82	5
PAE 240M3	119.7	1/5	3360	27.6	399.1	230	1.24	8
PAE130M2	119.7	1/18	1680	13.8	180.0	230	0.54	3.15
PAE165M3	119.7	1/14	1680	13.8	278.8	230	0.64	4
PAE 260M2T	119.7	1/8	3360	27.6	199.1	460 Y	0.29 Y	-
PAE 440M3T	119.7	1/4	3360	27.6	550.5	460 Y	0.52 Y	-
PAE140M2T	119.7	1/16	1680	13.8	230.0	460 Y	0.19 Y	-
PAE 230M3T	119.7	1/10	1680	13.8	431.0	460 Y	0.34 Y	-
PAE180M2	164.6	1/8	3360	20.4	275.2	230	0.82	5
PAE 240M3	164.6	1/5	3360	20.4	550.5	230	1.24	8
PAE130M2	164.6	1/18	1680	10.2	246.9	230	0.54	3.15
PAE165M3	164.6	1/14	1680	10.2	386.7	230	0.64	4
PAE 260M2T	164.6	1/8	3360	20.4	275.2	460 Y	0.29 Y	-
PAE 440M3T	164.6	1/4	3360	20.4	758.4	460 Y	0.52 Y	-
PAE140M2T	164.6	1/16	1680	10.2	319.5	460 Y	0.19 Y	-
PAE 230M3T	164.6	1/10	1680	10.2	594.7	460 Y	0.34 Y	-



# PAE

Type Tipo	Ratio Relación	Delivered power Potencia entregada	Input r.p.m. no-load Revoluciones entrada sin carga	Output r.p.m. no-load Revoluciones salida sin carga	Rated torque Par nominal	Voltage Tensión	Current Intensidad	Capacitor Condensador
	i	HP	rpm	rpm	in-lbs	Vac - 60 Hz	A	µF
PAE180M2	205.2	1/8	3360	16.3	343.4	230	0.82	5
PAE 240M3	205.2	1/5	3360	16.3	690.3	230	1.24	8
PAE130M2	205.2	1/18	1680	8.2	307.0	230	0.54	3.15
PAE165M3	205.2	1/14	1680	8.2	483.2	230	0.64	4
PAE 260M2T	205.2	1/8	3360	16.3	343.4	460 Y	0.29 Y	-
PAE 440M3T	205.2	1/4	3360	16.3	*796.5	460 Y	0.52 Y	-
PAE140M2T	205.2	1/16	1680	8.2	394.7	460 Y	0.19 Y	-
PAE 230M3T	205.2	1/10	1680	8.2	742.5	460 Y	0.34 Y	-
PAE180M2	293.9	1/8	3360	11.4	491.1	230	0.82	5
PAE 240M3	293.9	1/5	3360	11.4	*796.5	230	1.24	8
PAE130M2	293.9	1/18	1680	5.6	442.5	230	0.54	3.15
PAE165M3	293.9	1/14	1680	5.6	690.3	230	0.64	4
PAE 260M2T	293.9	1/8	3360	11.4	491.1	460 Y	0.29 Y	-
PAE 440M3T	293.9	1/4	3360	11.4	*796.5	460 Y	0.52 Y	-
PAE 140M2T	293.9	1/16	1680	5.6	566.4	460 Y	0.19 Y	-
PAE 230M3T	293.9	1/10	1680	5.6	*796.5	460 Y	0.34 Y	-
PAE180M2	404.1	1/8	3360	8.3	674.4	230	0.82	5
PAE 240M3	404.1	1/5	3360	8.3	*796.5	230	1.24	8
PAE130M2	404.1	1/18	1680	4.1	610.7	230	0.54	3.15
PAE165M3	404.1	1/14	1680	4.1	*796.5	230	0.64	4
PAE 260M2T	404.1	1/8	3360	8.3	674.4	460 Y	0.29 Y	-
PAE 440M3T	404.1	1/4	3360	8.3	*796.5	460 Y	0.52 Y	-
PAE140M2T	404.1	1/16	1680	4.1	782.3	460 Y	0.19 Y	-
PAE 230M3T	404.1	1/10	1680	4.1	*796.5	460 Y	0.34 Y	-
PAE180M2	503.8	1/8	3360	6.6	*796.5	230	0.82	5
PAE130M2	503.8	1/18	1680	3.2	762.0	230	0.54	3.15
PAE165M3	503.8	1/14	1680	3.2	*796.5	230	0.64	4
PAE 260M2T	503.8	1/8	3360	6.66	*796.5	460 Y	0.29 Y	-
PAE140M2T	503.8	1/16	1680	3.2	*796.5	460 Y	0.19 Y	-
PAE180M2	721.4	1/8	3360	4.6	*796.5	230	0.82	5
PAE130M2	721.4	1/18	1680	2.3	*796.5	230	0.54	3.15
PAE 260M2T	721.4	1/8	3360	4.6	*796.5	460 Y	0.29 Y	-
PAE140M2T	721.4	1/16	1680	2.3	*796.5	460 Y	0.19 Y	-
PAE180M2	992	1/8	3360	3.4	*796.5	230	0.82	5
PAE130M2	992	1/18	1680	1.7	*796.5	230	0.54	3.15
PAE 260M2T	992	1/8	3360	3.4	*796.5	460 Y	0.29 Y	-
PAE140M2T	992	1/16	1680	1.7	*796.5	460 Y	0.19 Y	-
PAE 180M2	1236.8	1/8	3360	2.6	*796.5	230	0.82	5
PAE130M2	1236.8	1/18	1680	1.3	*796.5	230	0.54	3.15
PAE 260M2T	1236.8	1/8	3360	2.6	*796.5	460 Y	0.29 Y	-
PAE140M2T	1236.8	1/16	1680	1.3	*796.5	460 Y	0.19 Y	-



Type Tipo	Ratio Relación	Delivered power Potencia entregada	Input r.p.m. no-load Revoluciones entrada sin carga	Output r.p.m. no-load Revoluciones salida sin carga	Rated torque Par nominal	Voltage Tensión	Current Intensidad	Capacitor Condensador
	i	HP	rpm	rpm	in-lbs	Vac - 60 Hz	A	μF
PAE180M2	1770.9	1/8	3360	1.8	*796.5	230	0.82	5
PAE130M2	1770.9	1/18	1680	0.8	*796.5	230	0.54	3.15
PAE 260M2T	1770.9	1/8	3360	1.8	*796.5	460 √	0.29 √	-
PAE140M2T	1770.9	1/16	1680	0.8	*796.5	460 √	0.19 √	-

(\*) - Under no circumstances should the torque values marked with an asterisk be exceeded. as for the higher gear ratios the motor power is considerably higher than the capacity of the gear unit.

(\*) - Los valores referentes al par marcados con el asterisco. no se deben en absoluto superar. ya que. con las altas relaciones. la potencia del motor es notablemente mayor que la capacidad del reductor.

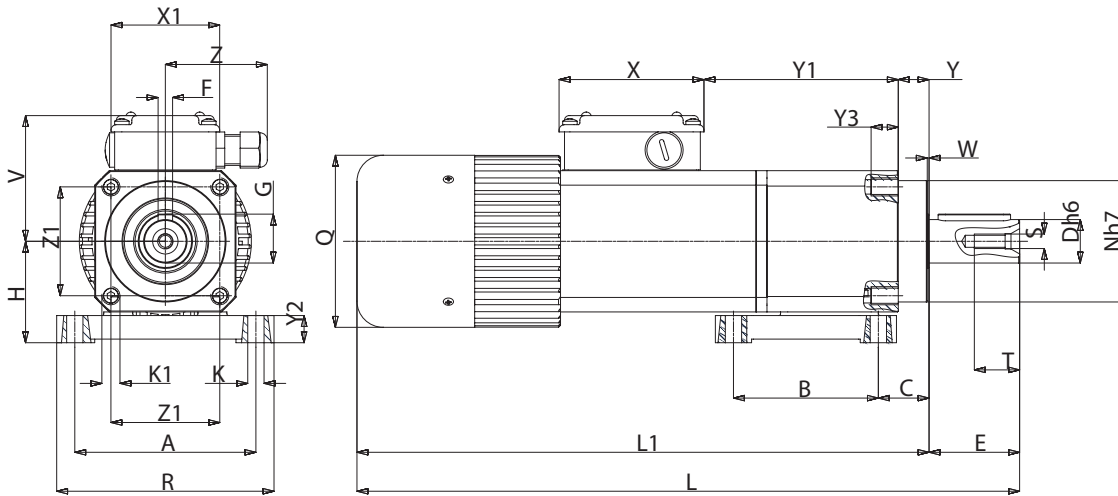

## B3

Type Tipo	A	B	C	D	E	F	G	H	K	K1	L	L1	N	Q
PAE...M2	3.937	3.149	1.102	0.944	1.968	0.314	1.062	2.204	0.354	M10	14.448	12.480	2.637	3.740
PAE...M3	3.937	3.149	1.102	0.944	1.968	0.314	1.062	2.204	0.354	M10	15.433	13.464	2.637	3.740

Type Tipo	R	S	T	V	X	X1	Y	Y1	Y2	Y3	W	Z	Z1	Weight Peso lbs
PAE...M2	4.724	M8	0.866	2.795	3.149	2.362	0.669	4.251	0.590	0.590	0.039	2.204	2.362	15.43
PAE...M3	4.724	M8	0.866	2.795	3.149	2.362	0.669	4.251	0.590	0.590	0.039	2.204	2.362	17.10



# PAE

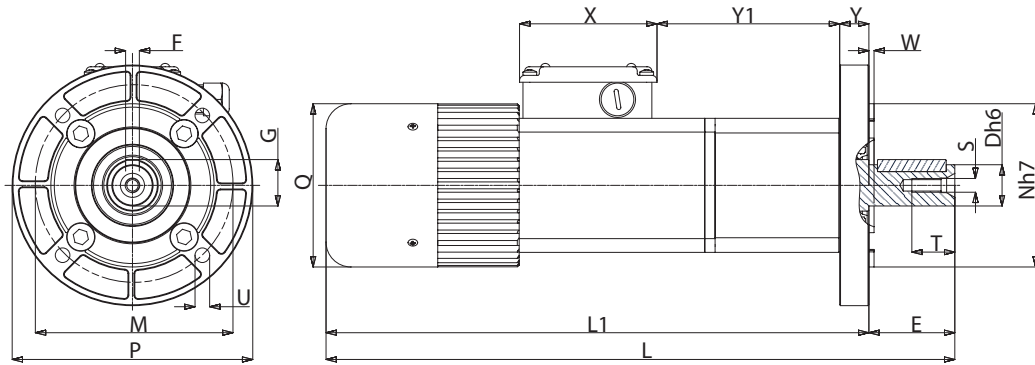

## B5

Type Tipo	D	E	F	G	L	L1	M	N	P
PAE...M2	0.944	1.968	0.314	1.062	14.448	12.480	4.527	3.740	5.511
PAE...M3	0.944	1.968	0.314	1.062	15.433	13.464	4.527	3.740	5.511

Type Tipo	Q	S	T	U	X	Y	Y1	W	Weight Peso lbs
PAE...M2	3.740	M8	0.866	0.354	3.149	0.669	4.251	0.118	15.43
PAE...M3	3.740	M8	0.866	0.354	3.149	0.669	4.251	0.118	17.13

For the self-braking version, add the letter KA or KB to the type designation. Dimensions L, L1, increase by 0.984 inch.

En la versión freno, añadir las letras KA ó KB a la sigla del tipo. Las cotas L, L1 aumentan de 0.984 inch.