



N.B. For the correct choice of the gearmotor, please refer to the tables on page 118. Refer to AM series page 12 for motor revs under load. These geared motors require a running-in period. Therefore, during the first 30 working hours, the resulting torque will be lower than the values given. On request, motor may be supplied with electromagnetic brake at 230 Vac, marked with letter KA (PCKA), or at 24 Vdc, marked with letter KB (PCKB), see specifications on page 120.

N.B. Para una selección correcta del motorreductor se aconseja ajustarse a las tablas presentadas en la página 118. Para las revoluciones motor bajo carga hágase referencia a la serie AM en la pág. 12. Estos motorreductores necesitan un cierto rodaje. Por lo tanto, en las primeras 30 horas de funcionamiento, se notará un par menor que los datos presentados. A petición es posible suministrar el motor con freno electromagnético alimentado con 230 Vca. que se distingue por la letra KA (PCKA), ó 24 Vdc. que se distingue por las letras KB (PCKB), ver características en la pág. 120.

WORM SCREW GEAR MOTOR

MOTOR: Asynchronous single or three phase with 2 or 4 poles, totally enclosed with external ventilation. Thermal safety cutout on single phase models. Class F windings. IP65 protection according to CEI EN 60529.

GEAR UNIT: With die-cast aluminum housing. Worm Center Distance 1.260 inches. CARO bronze gear ring with 120-160 HB hardness. Hardened steel worm with ground threads rotating on ball and roller bearings. Lubricated with synthetic oil. High temperature oil seals. 9 reduction gear ratios (i) are available from 7 to 100. Maximum rated torque 177.0 in-lbs. Versions B3 and B5. B5/S Left Version – B5/D Right Version.

MOTORREDUCTOR CON TORNILLO SIN FIN

MOTOR: *asíncrono monofásico o trifásico de 2 ó 4 polos, en forma cerrada con ventilación externa. Protector térmico de seguridad en el tipo monofásico. Aislamiento clase F. Protección IP 65 según normas CEI EN 60529.*

REDUCTOR: *con carcasa de aluminio inyectado a presión. Distancia entre ejes in 1.260. Corona de bronce CARO, dureza 120-160 HB. Tornillo de acero templado con filete rectificado que gira sobre cojinetes de bolas. Lubricación con aceite especial de larga duración. Retenes de estanqueidad de goma especial para altas temperaturas. Las relaciones de reducción disponibles (i) son 9, de 7 a 100. Par nominal 177.0 in-lbs. Versión B3 ó B5. B5/S izquierdo - B5/D derecho.*

PC



Type	Ratio	Delivered power	Input r.p.m. no-load	Output r.p.m. no-load	Rated torque	Voltage	Current	Capacitor
Tipo	Relación	Potencia entregada	Revoluciones entrada sin carga	Revoluciones salida sin carga	Par nominal	Tensión	Intensidad	Condensador
	i	HP	rpm	rpm	in-lbs	Vac - 60 Hz	A	µF
PC 240M3	7	1/5	3360	480	29.2	115 1Ø	2.47	32
PC 330M4	7	1/3	3360	480	40.7	115 1Ø	3.60	40
PC 165M3	7	1/14	1680	240	20.4	115 1Ø	1.28	16
PC 220M4	7	1/9	1680	240	29.2	115 1Ø	1.68	20
PC 440M3T	7	1/4	3360	480	37.2	230 3Ø	1.08	-
PC 530M4T	7	1/2	3360	480	54.9	230 3Ø	1.68	-
PC 230M3T	7	1/10	1680	240	29.2	230 3Ø	0.70	-
PC 310M4T	7	1/7	1680	240	40.7	230 3Ø	0.93	-
PC 240M3	10	1/5	3360	336	39.8	115 1Ø	2.47	32
PC 330M4	10	1/3	3360	336	55.8	115 1Ø	3.60	40
PC 165M3	10	1/14	1680	168	27.4	115 1Ø	1.28	16
PC 220M4	10	1/9	1680	168	39.8	115 1Ø	1.68	20
PC 440M3T	10	1/4	3360	336	51.3	230 3Ø	1.08	-
PC 530M4T	10	1/2	3360	336	75.2	230 3Ø	1.68	-
PC 230M3T	10	1/10	1680	168	38.9	230 3Ø	0.70	-
PC 310M4T	10	1/7	1680	168	55.8	230 3Ø	0.93	-
PC 240M3	20	1/5	3360	168	70.8	115 1Ø	2.47	32
PC 330M4	20	1/3	3360	168	100.9	115 1Ø	3.60	40
PC 165M3	20	1/14	1680	84	49.6	115 1Ø	1.28	16
PC 220M4	20	1/9	1680	84	70.8	115 1Ø	1.68	20
PC 440M3T	20	1/4	3360	168	92.0	230 3Ø	1.08	-
PC 530M4T	20	1/2	3360	168	136.3	230 3Ø	1.68	-
PC 230M3T	20	1/10	1680	84	70.8	230 3Ø	0.70	-
PC 310M4T	20	1/7	1680	84	99.1	230 3Ø	0.93	-
PC 240M3	30	1/5	3360	112	97.3	115 1Ø	2.47	32
PC 330M4	30	1/3	3360	112	137.2	115 1Ø	3.60	40
PC 165M3	30	1/14	1680	56	68.1	115 1Ø	1.28	16
PC 220M4	30	1/9	1680	56	97.3	115 1Ø	1.68	20
PC 440M3T	30	1/4	3360	112	125.7	230 3Ø	1.08	-
PC 530M4T	30	1/2	3360	112	*177.0	230 3Ø	1.68	-
PC 230M3T	30	1/10	1680	56	97.3	230 3Ø	0.70	-
PC 310M4T	30	1/7	1680	56	135.4	230 3Ø	0.93	-
PC 240M3	40	1/5	3360	84	122.1	115 1Ø	2.47	32
PC 330M4	40	1/3	3360	84	173.5	115 1Ø	3.60	40
PC 165M3	40	1/14	1680	42	68.1	115 1Ø	1.28	16
PC 220M4	40	1/9	1680	42	122.1	115 1Ø	1.68	20
PC 440M3T	40	1/4	3360	84	159.3	230 3Ø	1.08	-
PC 530M4T	40	1/2	3360	84	*177.0	230 3Ø	1.68	-
PC 230M3T	40	1/10	1680	42	122.1	230 3Ø	0.70	-
PC 310M4T	40	1/7	1680	42	171.7	230 3Ø	0.93	-



PC

Type	Ratio	Delivered power	Input r.p.m. no-load	Output r.p.m. no-load	Rated torque	Voltage	Current	Capacitor
Tipo	Relación	Potencia entregada	Revoluciones entrada sin carga	Revoluciones salida sin carga	Par nominal	Tensión	Intensidad	Condensador
	i	HP	rpm	rpm	in-lbs	Vac - 60 Hz	A	µF
PC 240M3	50	1/5	3360	67	148.7	115 1Ø	2.47	32
PC 330M4	50	1/3	3360	67	*177.0	115 1Ø	3.60	40
PC 165M3	50	1/14	1680	34	103.5	115 1Ø	1.28	16
PC 220M4	50	1/9	1680	34	150.4	115 1Ø	1.68	20
PC 440M3T	50	1/4	3360	67	*177.0	230 3Ø	1.08	-
PC 230M3T	50	1/10	1680	34	147.8	230 3Ø	0.70	-
PC 310M4T	50	1/7	1680	34	*177.0	230 3Ø	0.93	-
PC 240M3	60	1/5	3360	55	*159.3	115 1Ø	2.47	32
PC 165M3	60	1/14	1680	28	123.9	115 1Ø	1.28	16
PC 220M4	60	1/9	1680	28	*159.3	115 1Ø	1.68	20
PC 440M3T	60	1/4	3360	55	*159.3	230 3Ø	1.08	-
PC 230M3T	60	1/10	1680	28	*159.3	230 3Ø	0.70	-
PC 240M3	70	1/5	3360	48	*150.4	115 1Ø	2.47	32
PC 165M3	70	1/14	1680	24	127.4	115 1Ø	1.28	16
PC 440M3T	70	1/4	3360	48	*150.4	230 3Ø	1.08	-
PC 230M3T	70	1/10	1680	24	*150.4	230 3Ø	0.70	-
PC 240M3	100	1/5	3360	34	*115.0	115 1Ø	2.47	32
PC 165M3	100	1/14	1680	17	*115.0	115 1Ø	1.28	16
PC 440M3T	100	1/4	3360	34	*115.0	230 3Ø	1.08	-
PC 230M3T	100	1/10	1680	17	*115.0	230 3Ø	0.70	-

(*) - Under no circumstances should the torque values marked with an asterisk be exceeded. With the higher gear ratios the motor power is considerably higher than the capacity of the gear unit.

(*) - Los valores referentes al par marcados con el asterisco, no se deben en absoluto superar, ya que, con las altas relaciones, la potencia del motor es notablemente mayor que la capacidad del reductor.

Also available in 230 Vac single phase input.
 Also available in 460 Vac three phase input.
 Note - 230 Vac three phase suitable at 208 Vac.

Disponible también con entrada monofásica de 230 Vca.
 Disponible también con entrada trifásica de 460 Vca.
 Nota - 230 Vca trifásica adecuada para 208 Vca.

PC

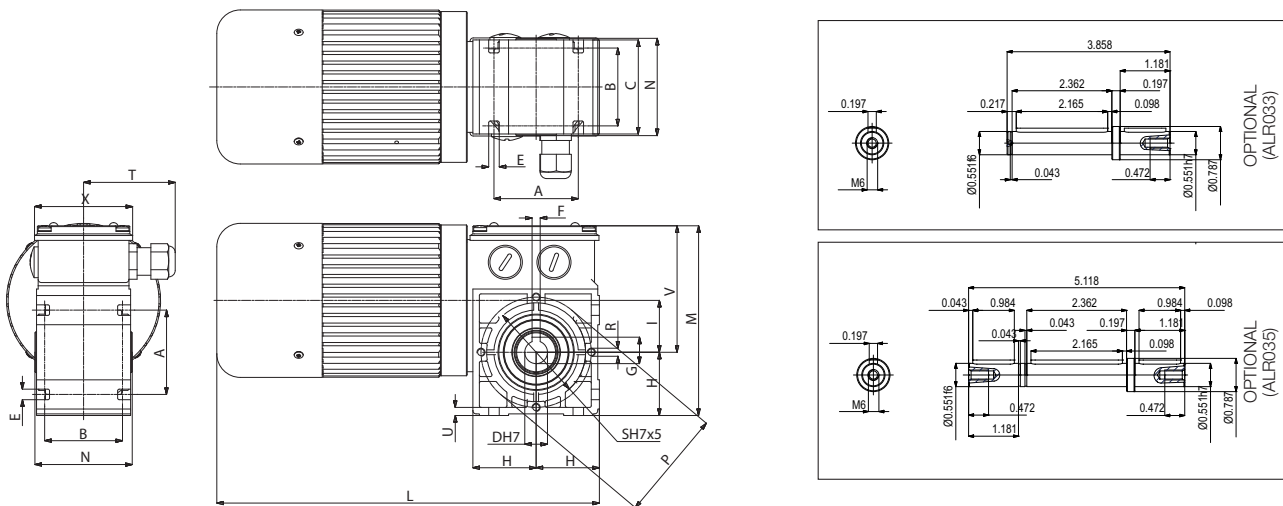

B3

Type Tipo	A	B	C	D	E	F	G	H	I	L	M
PC...M3	2.047	1.890	2.283	0.551	0.256	0.197	0.642	1.535	1.260	9.291	4.685
PC...M4	2.047	1.890	2.283	0.551	0.256	0.197	0.642	1.535	1.260	10.472	4.685

Type Tipo	N	P	Q	R	S	T	U	V	X	Weight Peso lbs
PC...M3	2.362	2.677	3.740	M5	2.402	2.205	0.197	3.150	2.362	8.97
PC...M4	2.362	2.677	3.470	M5	2.402	2.205	0.197	3.150	2.362	11.07

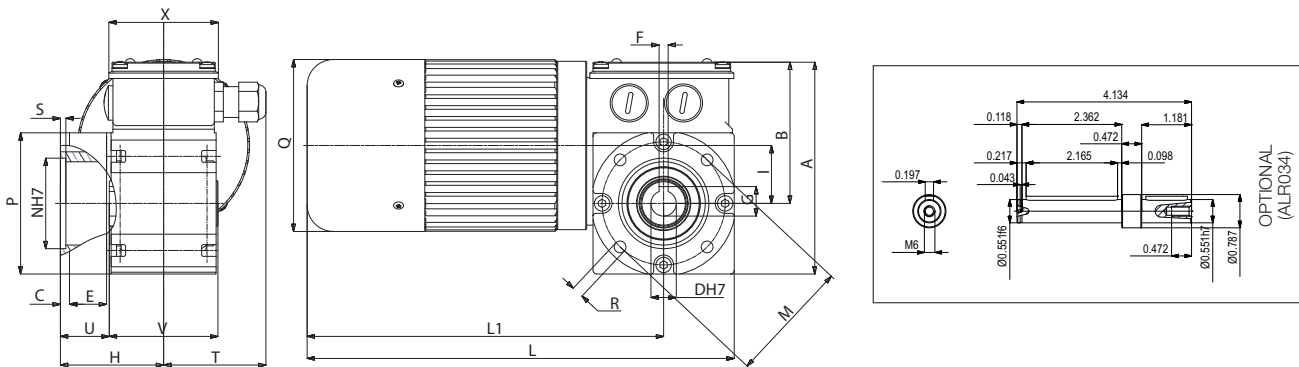

B5/S

Type Tipo	A	B	C	D	E	F	G	H	I	L	L1
PC...M3	4.685	3.150	0.197	0.551	0.728	0.197	0.642	2.165	1.260	9.291	7.756
PC...M4	4.685	3.150	0.197	0.551	0.728	0.197	0.642	2.165	1.260	10.472	8.937

Type Tipo	M	N	P	Q	R	S	T	U	V	X	Weight Peso lbs
PC...M3	2.677	1.969	3.150	3.740	0.256	0.118	2.205	0.118	0.984	2.362	9.26
PC...M4	2.677	1.969	3.150	3.740	0.256	0.118	2.205	0.984	2.362	2.362	11.36

For the self-braking version, add the letter KA or KB to the type designation. Dimensions L, L1, increase by 0.984 in.

En la versión freno, añadir las letras KA ó KB a la sigla del tipo. Las cotas L, L1 aumentan de 0.984 in.