



N.B. For the correct choice of the gearmotor, please refer to the tables on page 118. These gear motors require a running-in period. Therefore, during the first 30 working hours, the resulting torque will be lower than the values given.

N.B. Para una selección correcta del motorreductor se aconseja ajustarse a las tablas presentadas en la página 118. Estos motorreductores necesitan un cierto rodaje. Por lo tanto, en las primeras 30 horas de funcionamiento, se notará un par menor que los datos presentados.

WORM SCREW GEAR MOTOR WITH PLANETARY REDUCTION GEAR

MOTOR: Direct Current with permanent magnets. Totally enclosed without external ventilation. Class F windings. Power supply with 12 or 24 Vdc. Max. absorbed power 230 W. IP65 protection according to CEI EN 60529.

GEAR UNIT: With die-cast aluminum worm housing reduction and steel planetary housing reduction with three internal planetary gears, ratio $i = 4.75$. Worm Center Distance 1.260 inches. CARO bronze gear ring with 120-160 HB hardness. Hardened steel worm with ground threads rotating on ball and roller bearings. Lubricated with synthetic oil. High temperature oil seals. 9 reduction gear ratios (i) are available from 33.25 to 475. Maximum rated torque 717.0 in-lbs. Versions B3 and B5. B5/S Left Version – B5/D Right Version.

MOTORREDUCTOR DE TORNILLOS SIN FIN CON REDUCTOR EPICICLOIDAL

MOTOR: de corriente continua con imanes permanentes, en forma cerrada sin ventilación externa. Aislamiento clase F. Alimentación con 12 ó 24 Vdc. Potencia máx. absorbida 230 W. Protección IP 65 según normas CEI EN 60529.

REDUCTOR: con carcasa de aluminio inyectado a presión en la primera etapa de reducción con tornillo sin fin, y de acero en la segunda etapa de reducción de tipo epicicloidal con tres satélites internos. Corona de bronce CARO, dureza 120-160 HB. Tornillo de acero templado con filete rectificadado que gira sobre cojinetes de bolas. Lubricación con aceite especial de larga duración. Retenes de estanqueidad de goma especial para altas temperaturas. Las relaciones de reducción disponibles (i) son 9, de 33.25 a 475. Par nominal 717 in-lbs. Versión B3 ó B5. B5/S izquierdo - B5/D derecho.



PCCE

Type	Ratio	Voltage	Current	Absorbed power	Delivered power	Input r.p.m.	Output r.p.m.	Rated torque
Tipo	Relación	Tensión	Intensidad	Potencia absorbida	Potencia entregada	Revoluciones entrada	Revoluciones salida	Par nominal
	i	V	A	W	HP	rpm	rpm	in-lbs
PCCE 12MP3N	33.25	12	9.6	115	1/10	2800	84	68
PCCE 12MP4N	33.25	12	19.2	230	1/5	2800	84	133
PCCE 24MP3N	33.25	24	4.8	115	1/10	2800	84	68
PCCE 24MP4N	33.25	24	9.6	230	1/5	2800	84	133
PCCE 12MP3N	47.5	12	9.6	115	1/10	2800	59	92
PCCE 12MP4N	47.5	12	19.2	230	1/5	2800	59	184
PCCE 24MP3N	47.5	24	4.8	115	1/10	2800	59	92
PCCE 24MP4N	47.5	24	9.6	230	1/5	2800	59	184
PCCE 12MP3N	95	12	9.6	115	1/10	2800	30	159
PCCE 12MP4N	95	12	19.2	230	1/5	2800	30	319
PCCE 24MP3N	95	24	4.8	115	1/10	2800	30	159
PCCE 24MP4N	95	24	9.6	230	1/5	2800	30	319
PCCE 12MP3N	142.5	12	9.6	115	1/10	2800	20	227
PCCE 12MP4N	142.5	12	19.2	230	1/5	2800	20	455
PCCE 24MP3N	142.5	24	4.8	115	1/10	2800	20	227
PCCE 24MP4N	142.5	24	9.6	230	1/5	2800	20	455
PCCE 12MP3N	190	12	9.6	115	1/10	2800	15	280
PCCE 12MP4N	190	12	19.2	230	1/5	2800	15	559
PCCE 24MP3N	190	24	4.8	115	1/10	2800	15	280
PCCE 24MP4N	190	24	9.6	230	1/5	2800	15	559
PCCE 12MP3N	237.5	12	9.6	115	1/10	2800	12	348
PCCE 12MP4N	237.5	12	19.2	230	1/5	2800	12	696
PCCE 24MP3N	237.5	24	4.8	115	1/10	2800	12	348
PCCE 24MP4N	237.5	24	9.6	230	1/5	2800	12	696
PCCE 12MP3N	285	12	9.6	115	1/10	2800	10	358
PCCE 12MP4N	285	12	16.6	200	1/6	2900	10.2	717
PCCE 24MP3N	285	24	4.8	115	1/10	2800	10	358
PCCE 24MP4N	285	24	8.3	200	1/6	2900	10.2	717
PCCE 12MP3N	332.5	12	9.6	115	1/10	2800	8.4	427
PCCE 12MP4N	332.5	12	16	192	1/6	2900	8.7	681
PCCE 24MP3N	332.5	24	4.8	115	1/10	2800	8.4	427
PCCE 24MP4N	332.5	24	8	192	1/6	2900	8.7	681
PCCE 12MP3N	475	12	9.6	115	1/10	2800	6	522
PCCE 24MP3N	475	24	4.8	115	1/10	2800	6	522

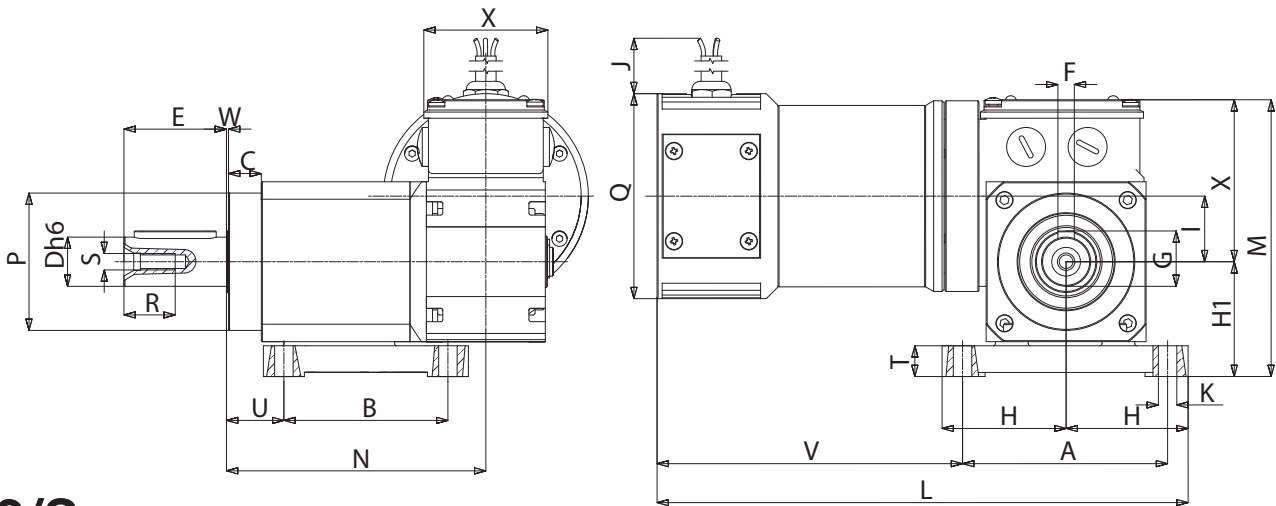

B3/S

Type Tipo	A	B	C	D	E	F	G	H	H1	J	K	I	L
PCCE...MP3N	3.937	3.150	0.630	0.945	1.968	0.315	1.063	2.362	2.205	20.472	0.354	1.260	10.197
PCCE...MP4N	3.937	3.150	0.630	0.945	1.968	0.315	1.063	2.362	2.205	20.472	0.354	1.260	12.166

Type Tipo	M	N	P	Q	R	S	T	U	V	W	X	Weight Peso lbs
PCCE...MP3N	3.354	5.000	2.638	3.937	0.866	M8	0.591	1.102	5.866	0.039	2.362	17.75
PCCE...MP4N	3.354	5.000	2.638	3.937	0.866	M8	0.591	1.102	7.835	0.039	2.362	21.93

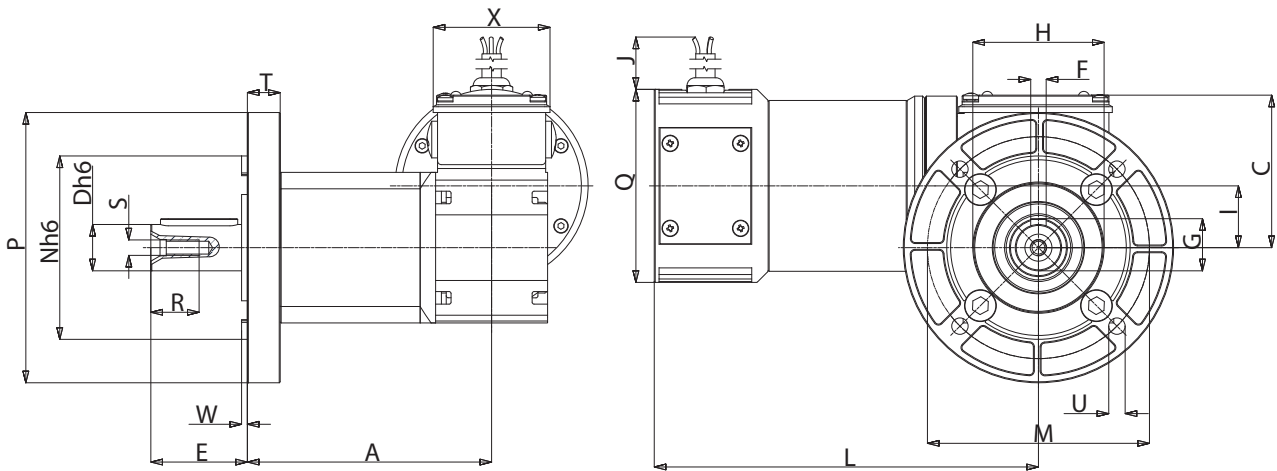

B5/S

Type Tipo	A	C	D	E	F	G	H	I	J	L	M
PCCE...MP3N	5.000	3.150	0.945	1.968	0.315	1.063	2.638	1.260	20.472	7.835	4.528
PCCE...MP4N	5.000	3.150	0.945	1.968	0.315	1.063	2.638	1.260	20.472	9.803	4.528

Type Tipo	N	P	Q	R	S	T	U	W	X	Weight Peso lbs
PCCE...MP3N	3.740	5.512	3.397	0.866	M8	0.670	0.354	0.118	2.362	17.77
PCCE...MP4N	3.740	5.512	3.397	0.866	M8	0.670	0.354	0.118	2.362	21.95